

# Service Manual

**PIONEER®**  
The Art of Entertainment

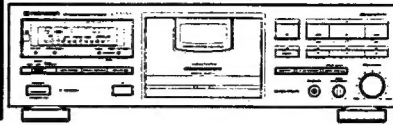

STEREO CASSETTE DECK

# CT-S520

## CT-S420

CT-S520 AND CT-S420 HAVE THE FOLLOWING:

Type	Model		Power Requirement	Remarks
	CT-S520	CT-S420		
HEM	○	○	AC220 - 230V, 230 - 240V (switchable) *	
HB	○	○	AC220 - 230V, 230 - 240V (switchable) *	

\*Change the connection of the power transformer's primary wiring.

- This manual is applicable to the following: CT-S520/HEM and HB; CT-S420/HEM and HB.
- The models and their types in this manual indicate the following:  
 CT-S520; CT-S520/HEM and HB types.  
 CT-S420; CT-S420/HEM and HB types.  
 HEM type; CT-S520/HEM and CT-S420/HEM.  
 HB type; CT-S520/HB and CT-S420/HB.

## CONTENTS

1. SAFETY INFORMATION .....	2	7. PCB PARTS LIST .....	22
2. PACKING AND PARTS LIST .....	3	8. ADJUSTMENTS .....	25
3. EXPLODED VIEWS AND PARTS LIST .....	4	9. IC INFORMATION .....	29
4. BLOCK DIAGRAM .....	10	10. FL INFORMATION .....	31
5. PCB CONNECTION DIAGRAM .....	11	11. PANEL FACILITIES .....	32
6. SCHEMATIC DIAGRAM .....	19	12. SPECIFICATIONS .....	33

**PIONEER ELECTRONIC CORPORATION** 4-1, Meguro 1-Chome, Meguro-ku, Tokyo 153, Japan  
**PIONEER ELECTRONICS SERVICE INC.** P.O. Box 1760, Long Beach, California 90801 U.S.A.  
**PIONEER ELECTRONICS OF CANADA, INC.** 300 Allstate Parkway Markham, Ontario L3R 0P2 Canada  
**PIONEER ELECTRONIC [EUROPE] N.V.** Haven 1087 Keetberglaan 1, 9120 Melsele, Belgium  
**PIONEER ELECTRONICS AUSTRALIA PTY. LTD.** 178-184 Boundary Road, Braeside, Victoria 3195, Australia TEL: [03] 580-9911  
 © PIONEER ELECTRONIC CORPORATION 1993

SF MAR. 1993 Printed in Japan

# 1. SAFETY INFORMATION

This service manual is intended for qualified service technicians; it is not meant for the casual do-it-yourselfer. Qualified technicians have the necessary test equipment and tools, and have been trained to properly and safely repair complex products such as those covered by this manual. Improperly performed repairs can adversely affect the safety and reliability of the product and may void the warranty. If you are not qualified to perform the repair of this product properly and safely, you should not risk trying to do so and refer the repair to a qualified service technician.



**WARNING**

Lead in solder used in this product is listed by the California Health and Welfare agency as a known reproductive toxicant which may cause birth defects or other reproductive harm (California Health & Safety Code, Section 25249.5).

When servicing or handling circuit boards and other components which contain lead in solder, avoid unprotected skin contact with the solder. Also, when soldering do not inhale any smoke or fumes produced.

**NOTICE**

(FOR CANADIAN MODEL ONLY)

Fuse symbols  (fast operating fuse) and/or  (slow operating fuse) on PCB indicate that replacement parts must be of identical designation.

**REMARQUE**

(POUR MODÈLE CANADIEN SEULEMENT)

Les symboles de fusible  (fusible de type rapide) et/ou  (fusible de type lent) sur CCI indiquent que les pièces de remplacement doivent avoir la même désignation.

(FOR USA MODEL ONLY)

## 1. SAFETY PRECAUTIONS

The following check should be performed for the continued protection of the customer and service technician.

### LEAKAGE CURRENT CHECK

Measure leakage current to a known earth ground (water pipe, conduit, etc.) by connecting a leakage current tester such as Simpson Model 229-2 or equivalent between the earth ground and all exposed metal parts of the appliance (input/output terminals, screwheads, metal overlays, control shaft, etc.). Plug the AC line cord of the appliance directly into a 120V AC 60Hz outlet and turn the AC power switch on. Any current measured must not exceed 0.5mA.

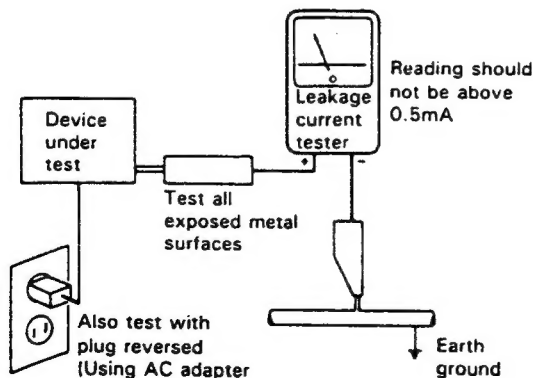

AC Leakage Test

ANY MEASUREMENTS NOT WITHIN THE LIMITS OUTLINED ABOVE ARE INDICATIVE OF A POTENTIAL SHOCK HAZARD AND MUST BE CORRECTED BEFORE RETURNING THE APPLIANCE TO THE CUSTOMER.

## 2. PRODUCT SAFETY NOTICE

Many electrical and mechanical parts in the appliance have special safety related characteristics. These are often not evident from visual inspection nor the protection afforded by them necessarily can be obtained by using replacement components rated for voltage, wattage, etc. Replacement parts which have these special safety characteristics are identified in this Service Manual.

Electrical components having such features are identified by marking with a  $\Delta$  on the schematics and on the parts list in this Service Manual.

The use of a substitute replacement component which does not have the same safety characteristics as the PIONEER recommended replacement one, shown in the parts list in this Service Manual, may create shock, fire, or other hazards.

Product Safety is continuously under review and new instructions are issued from time to time. For the latest information, always consult the current PIONEER Service Manual. A subscription to, or additional copies of, PIONEER Service Manual may be obtained at a nominal charge from PIONEER.

## 2. PACKING AND PARTS LIST

### NOTES:

- Parts marked by "NSP" are generally unavailable because they are not in our Master Spare Parts List.
- The  $\Delta$  mark found on some component parts indicates the importance of the safety factor of the part. Therefore, when replacing, be sure to use parts of identical designation.
- Parts marked by "⊙" are not always kept in stock. Their delivery time may be longer than usual or they may be unavailable.

### Parts List

Mark	No.	Description	Part No.
	1	Pad (L)	RHA1111
	2	Pad (R)	RHA1112
	3	Packing case (For CT-S520/HBM)	RHG1452
	3	Packing case (For CT-S520/HB)	RHG1459
	3	Packing case (For CT-S420/HBM)	RHG1453
	3	Packing case (For CT-S420/HB)	RHG1460
	4	Sheet	RHX - 034
	5	Connection cord (For AUDIO)	RDE - 010
	6	Control cord (For CD • DECK SYNCHRO)	RDE1030
	7	Operating instructions (German/Italian/Dutch/ Swedish/Spanish/Portuguese)	RRD1135
	8	Operating instructions (HEM type only)	RRE1076
	9	Remote control unit (CT-S520 only)	RPX1066
	10	Battery cover (CT-S520 only)	RZN1007
	11	Spacer A	RHC1044
	12	Cord with mini plug (For SR cord) (CT-S420 only)	PDE - 319
	13	Pad spacer A (HB type only)	RHC1039
	14	Pad spacer B (HB type only)	RHC1041
NSP	101	Battery (R6P, AA) (CT-S520 only)	VEM - 013

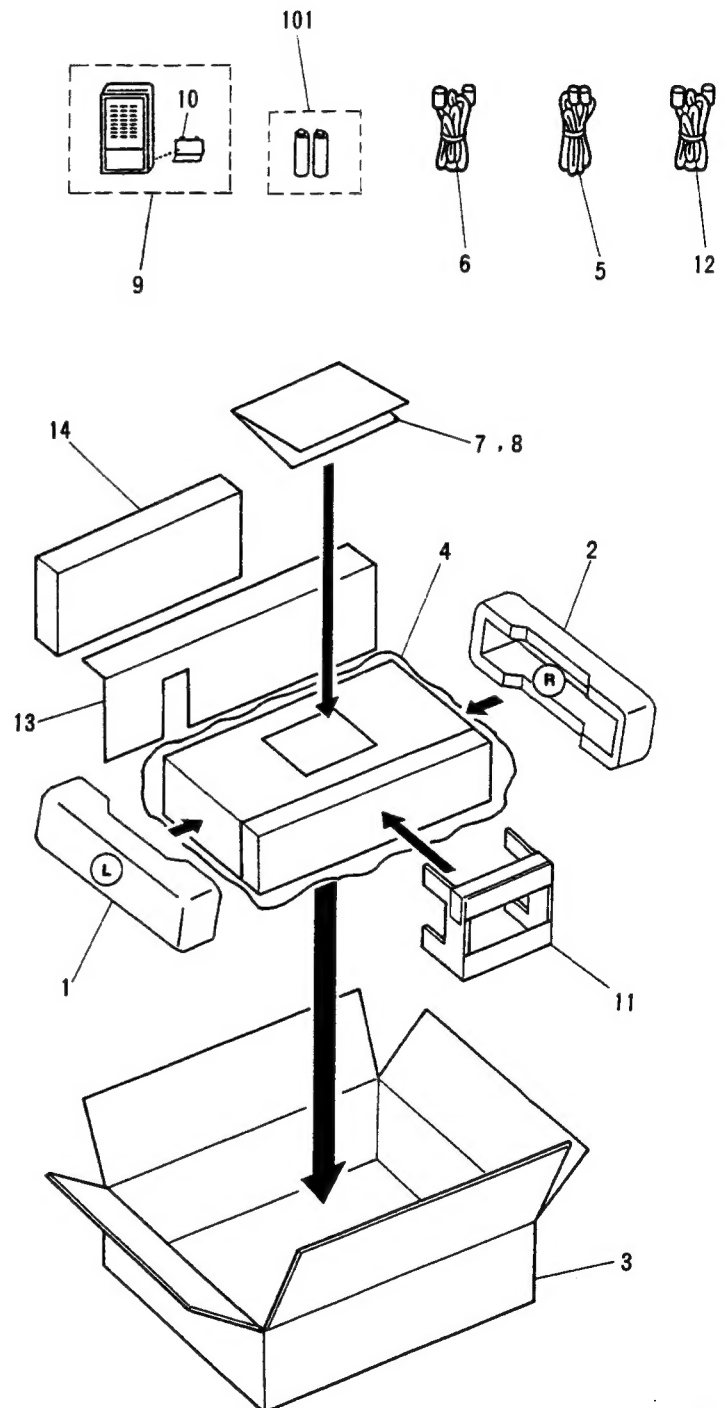

### 3. EXPLODED VIEWS AND PARTS LIST

#### 3.1 EXTERIOR

**NOTES:**

- Parts marked by "NSP" are generally unavailable because they are not in our Master Spare Parts List.
- The  $\Delta$  mark found on some component parts indicates the importance of the safety factor of the part. Therefore, when replacing, be sure to use parts of identical designation.
- Parts marked by "⊙" are not always kept in stock. Their delivery time may be longer than usual or they may be unavailable.

**Parts List**

Mark	No.	Description	Part No.	Mark	No.	Description	Part No.
$\Delta$	1	Strain relief	CM - 22B		36	Bonnet	REA1077
$\Delta$	2	AC power cord (For HEM type)	RDG1026		37	Front panel (For CT-S520)	RAH2234
$\Delta$	2	AC power cord (For HB type)	RDG1024		37	Front panel (For CT-S420)	RAH2235
$\Delta$	3	FU801, FU803 Fuse (T1AL250V)	REK - 100		38	Screw	ABZ30P080FMC
	4	Name plate	RAM1007		39	Screw	BBZ26P060FMC
$\Delta$	5	Power transformer (T1)	RTT1221		40	Screw	BBZ30P060FZK
	6	Cord clamper	RNH - 184		41	Screw	BBZ30P080FMC
	7	Ratchet spring (CT-S520 only)	RBH1008		42	Screw	BMZ26P040FMC
	8	Half pressure spring	RBK1004		43	Screw	IPZ20P080FMC
	9	Main unit (For CT-S520)	RWZ2885		44	Screw	IBZ30P150FCU
	9	Main unit (For CT-S420)	RWZ2877		45	Pulley gear (CT-S520 only)	RNK1517
	10	DISP unit (For CT-S520)	RWZ2887		46	Joint (CT-S520 only)	RNK1895
	10	DISP unit (For CT-S420)	RWZ2879		47	Cam gear (CT-S520 only)	RNK1896
	11	1/f unit	RWX1086		48	Binder	REC - 371
⊙	12	HX unit	RWX1069		49	Lead card 33P	RDD1284
	13	Insulator	PNW1912		50	Connector assembly 2P	RKP1384
	14	Lens S	PNW1893		51	SW lever (CT-S520 only)	RNK1897
	15	LED lens	PNW2019		52	Loading base assembly (CT-S520 only)	RXA1548
	16	VR knob	RAC1707		53	Eject knob (CT-S420 only)	RAC1772
	17	Power knob	RAC1809		54	Door spring L (CT-S420 only)	RBH1341
	18	Operation knob	RAC1795		55	Damper assembly (CT-S420 only)	REC1005
	19	Balance knob	RAC1705		56	Screw (CT-S420 only)	BCZ26P050FMC
	20	Mode knob A (For CT-S520)	RAC1798		57	Pin cap (HB type only)	VEC1616
	20	Mode knob A (For CT-S420)	RAC1800		58	Screw (CT-S420 only)	IBZ26P080FMC
	21	Slide knob	RAC1713	NSP	59	Eject spring (CT-S420 only)	RBH1342
	22	Mode knob B	RAC1808	NSP	60	Washer (CT-S420 only)	WA52D080D025
	23	Door lens (For CT-S520)	RAH2265	NSP	101	OPSW unit	RWZ2888
	23	Door lens (For CT-S420)	RAH2171	NSP	102	TRN 2 unit	RWZ2890
	24	Stabilizer panel	RAH1483	NSP	103	MECS unit (CT-S520 only)	RWZ2891
⊙	25	Mechanism unit (For CT-S520)	RYM1203	NSP	104	MECM unit (CT-S520 only)	RWZ2892
⊙	25	Mechanism unit (For CT-S420)	RYM1204	NSP	105	TRN 1 PCB	RNZ2390
	26	Screw (CT-S520 only)	PBA - 125	NSP	106	Mechanism bracket	RNE1601
	27	Stabilizer B	REB1085	NSP	107	Rear panel (For CT-S520)	RNA1681
	28	Remain display paper	REE - 113	NSP	107	Rear panel (For CT-S420)	RNA1682
	29	Door pocket (For CT-S520)	RAH2243	NSP	108	PCB spacer	PNY - 404
	29	Door pocket (For CT-S420)	RAH2230	NSP	109	Trans shield plate	RNE1451
	30	Door side panel R (CT-S520 only)	RAH2261	NSP	110	Main chassis	RNB1090
	31	Door side panel L (CT-S520 only)	RAH2262	NSP	111	Connector assembly 4P	RKP1111
	32	Rubber belt (CT-S520 only)	PEB1127	NSP	112	Connector assembly 4P	RKP1112
	33	Motor pulley (CT-S520 only)	PNW1634	NSP	113	Arm Collar (CT-S420 only)	RLA1124
	34	FL lens (For CT-S520)	RAH2239	NSP	114	Eject arm (CT-S420 only)	RNE1597
	34	FL lens (For CT-S420)	RAH2291				
4	35	DC motor (CT-S520 only)	PXM1010				

Exterior

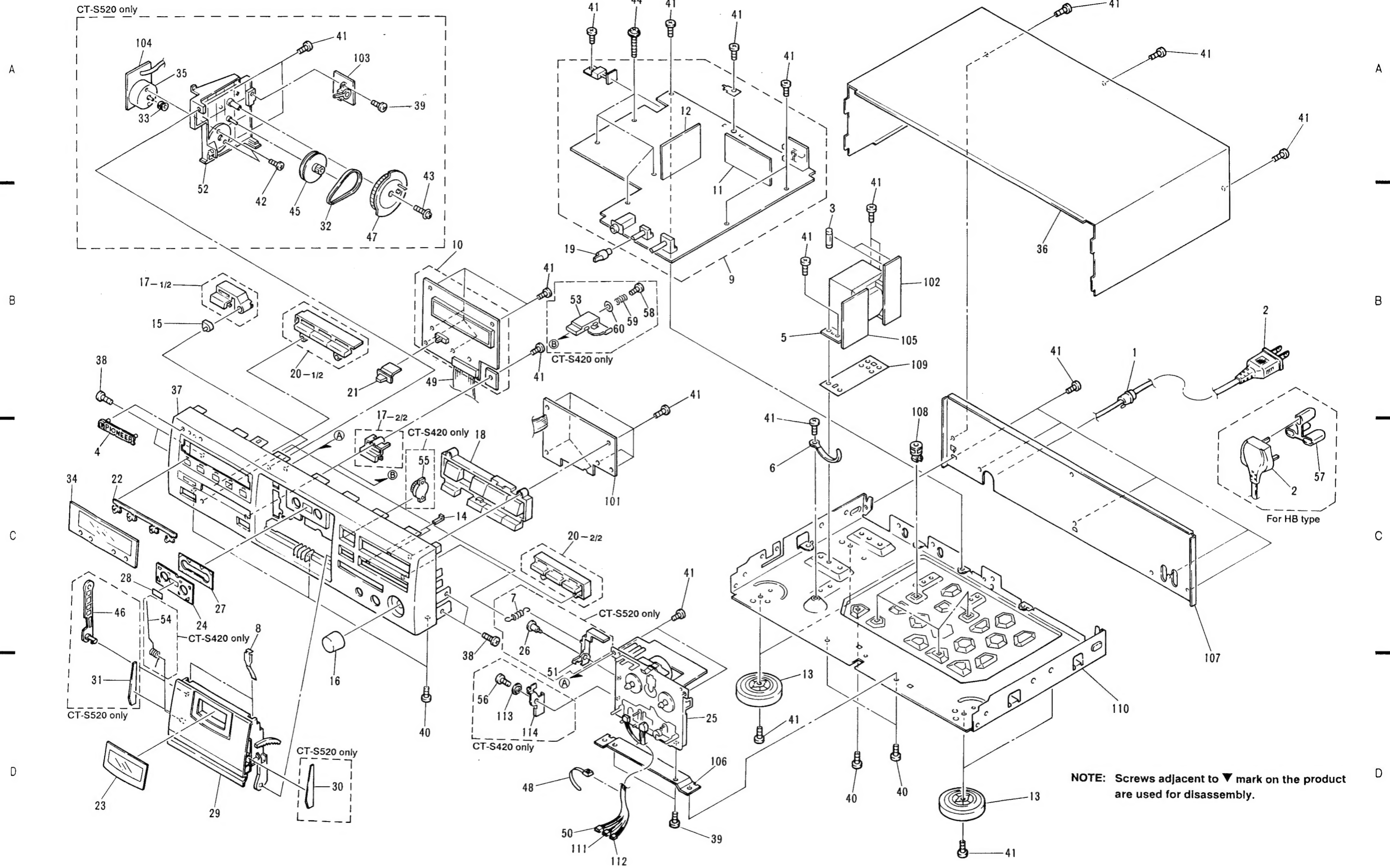

3.2 MECHANISM UNIT (RYM1203 and RYM1204)

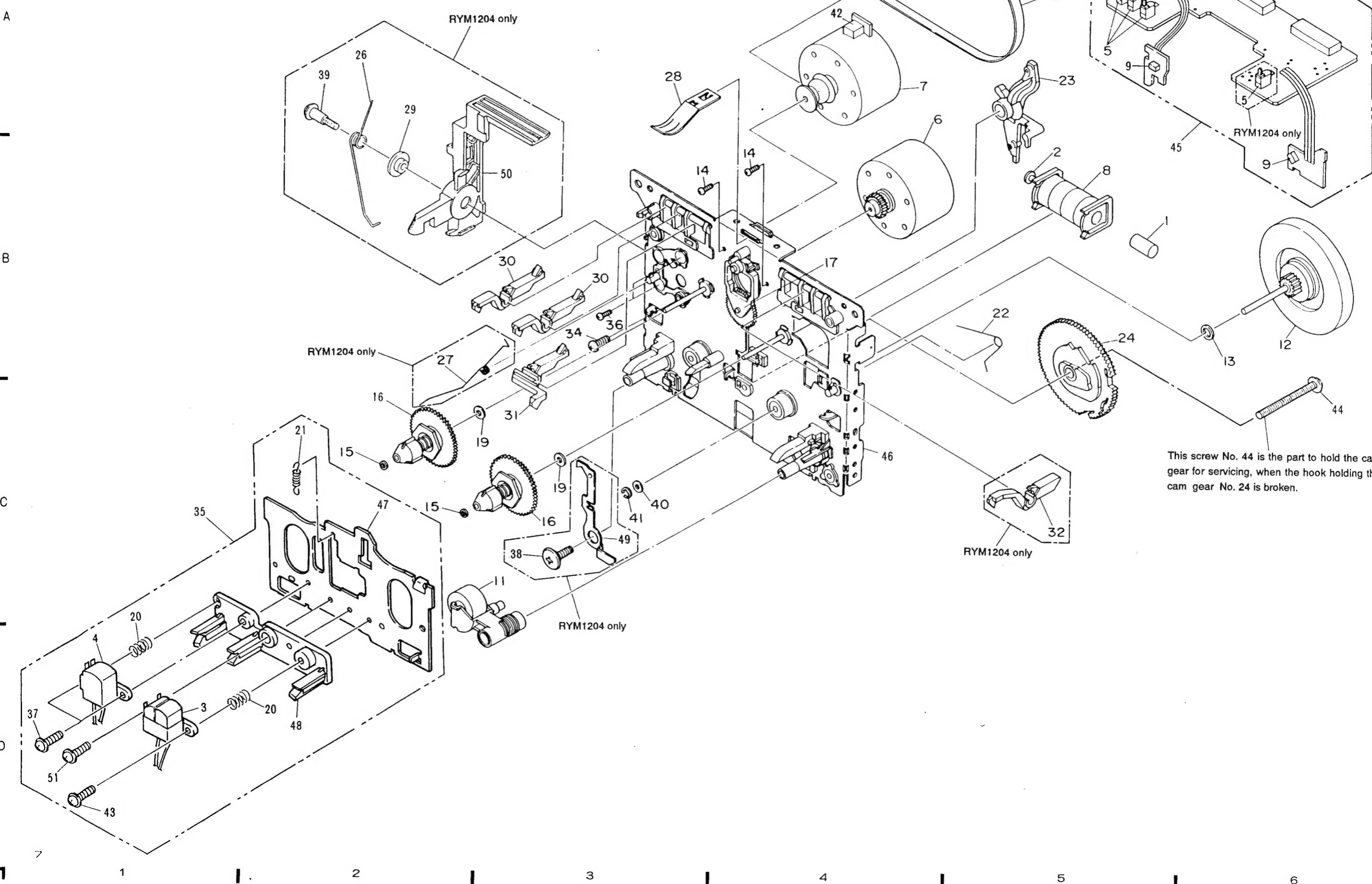

This screw No. 44 is the part to hold the cam gear for servicing, when the hook holding the cam gear No. 24 is broken.

### 4. BLOCK DIAGRAM

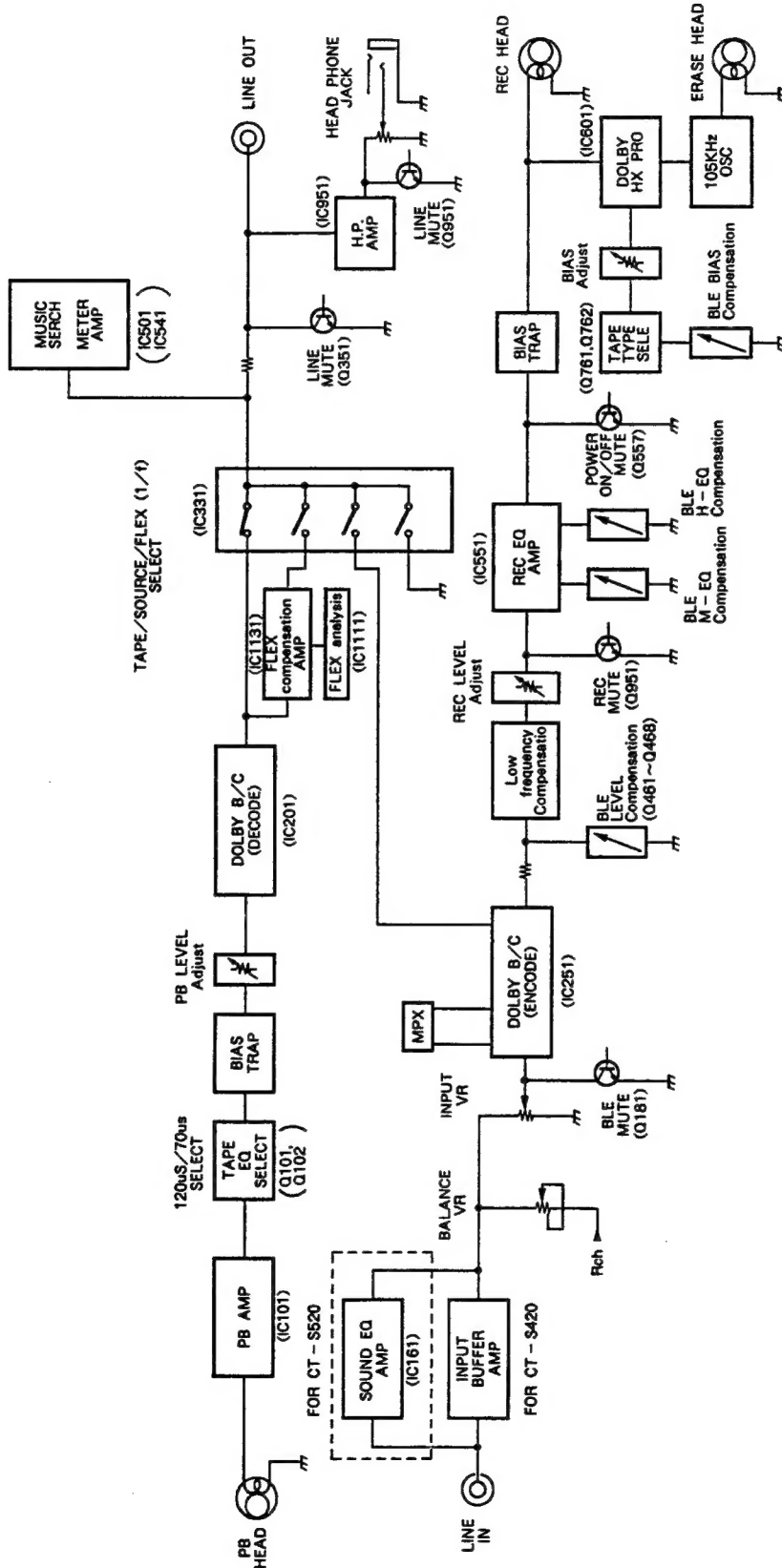

## Parts List

Mark	No.	Description	Part No.	Mark	No.	Description	Part No.
	1	Fixed core	RLA1130		46	Chassis base BLK	RXA1557
	2	Planger	RLA1132		47	Head base	RNE1390
	3	Head (R/P)	RPB1047		48	Head spacer	RNK1836
	4	Head (E)	RPB1040		49	Eject prevention arm (L)	RNE1199
	5	Push SW	RSG1018				(RYM1204 only)
	6	MTR reel BLK	RXM1057		50	Lever (L) (EJECT)	RNK1593
	7	MTR main BLK	RXM1058				(RYM1204 only)
	8	Solenoid BLK	RXP1010		51	Screw	PMZ20P080FMC
	9	Photo - transistor	SPI33534FG				
	10	Main belt	REB1163				
	11	Pinch roller ass'y	RXA1183				
	12	F/W ass'y	RXA1346				
	13	Washer	WA26D045D025				
	14	Pan 2.6 x 6.4 ZN	RBA1076				
	15	Washer	RBF - 057				
	16	Reel base BLK	RXA1184				
	17	Idler BLK	RXA1248				
	18	.....					
	19	Washer	RBF1038				
	20	Azimuth SP	RBH1076				
	21	Head base SP	RBL1003				
	22	Slide SP	RBH1239				
	23	Play arm	RNK1525				
	24	Cam gear (3R)	RNK1672				
	25	.....					
	26	Lever SP (L) (EJECT)	RBH1262				
			(RYM1204 only)				
	27	Eject prevention spring (L)	RBH1234				
			(RYM1204 only)				
	28	Spring (CASSETTE)	RBK1048				
	29	Lever collar B	RLA1146				
			(RYM1204 only)				
	30	Detector lever (REC)	RNK1527				
	31	Metal detector lever (L)	RNK1529				
	32	Detector lever (P)	RNK1543				
			(RYM1204 only)				
	33	.....					
	34	Screw	RBA1101				
	35	Plate HD BLK	RXA1488				
	36	Screw	PMA26P050FMC				
	37	F lock screw	RBA1031				
	38	Screw (7.7)	RBA1048				
			(RYM1204 only)				
	39	Screw	RBA1078				
			(RYM1204 only)				
	40	Washer	WA26D047D050				
	41	Washer	YE15FUC				
	42	Holder cushion (L)	RED1027				
	43	F lock screw	RBA1102				
	44	Screw	RBA1068				
	45	PCB control BLK	RXA1556				
			(RYM1203 only)				
			RXA1487				
			(RYM1204 only)				



# 5. PCB CONNECTION DIAGRAM

• View from soldering side

A

B

C

D

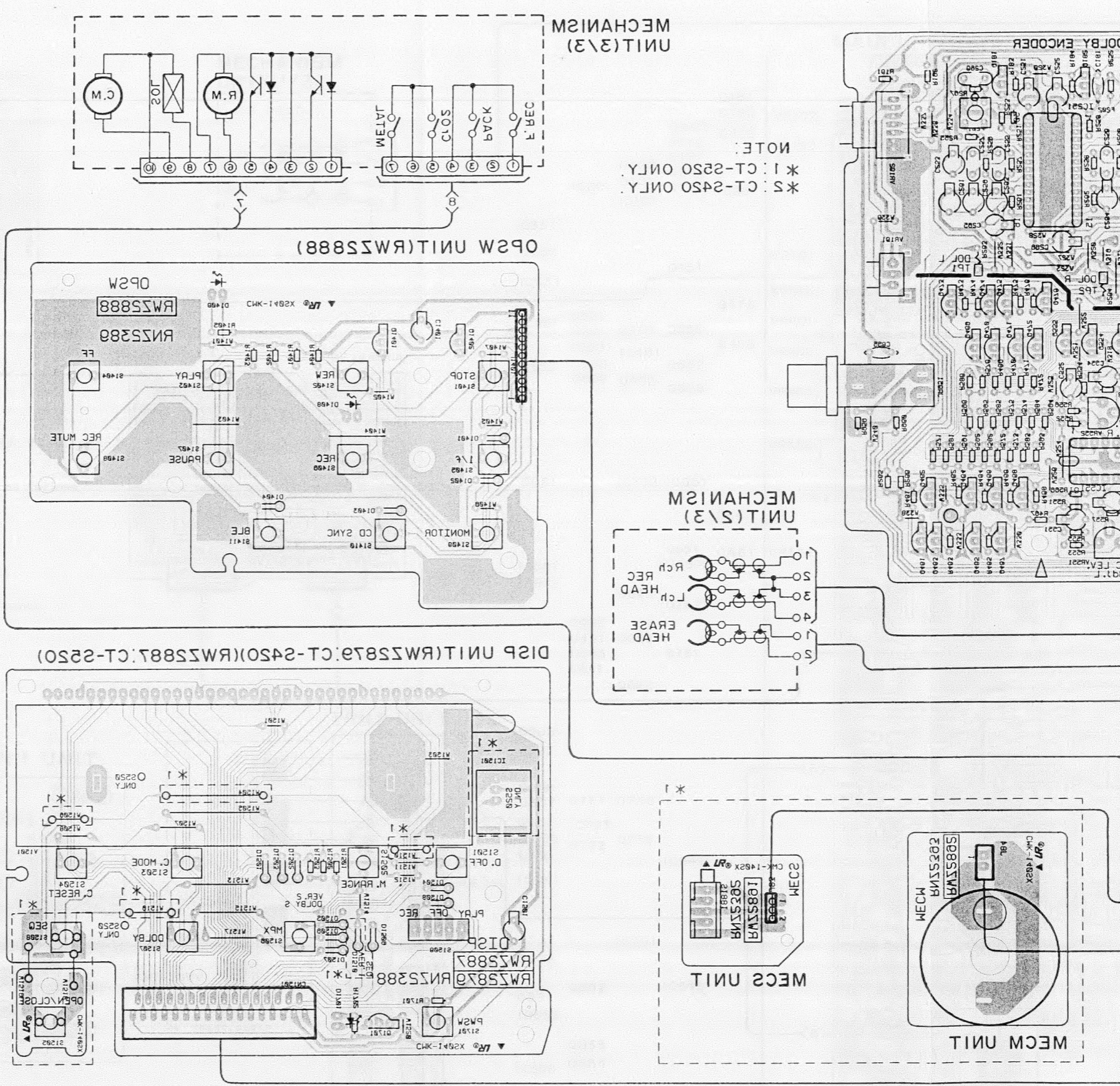

NOTE:  
\* 1: CT-2550 ONLY.  
\* 2: CT-2450 ONLY.

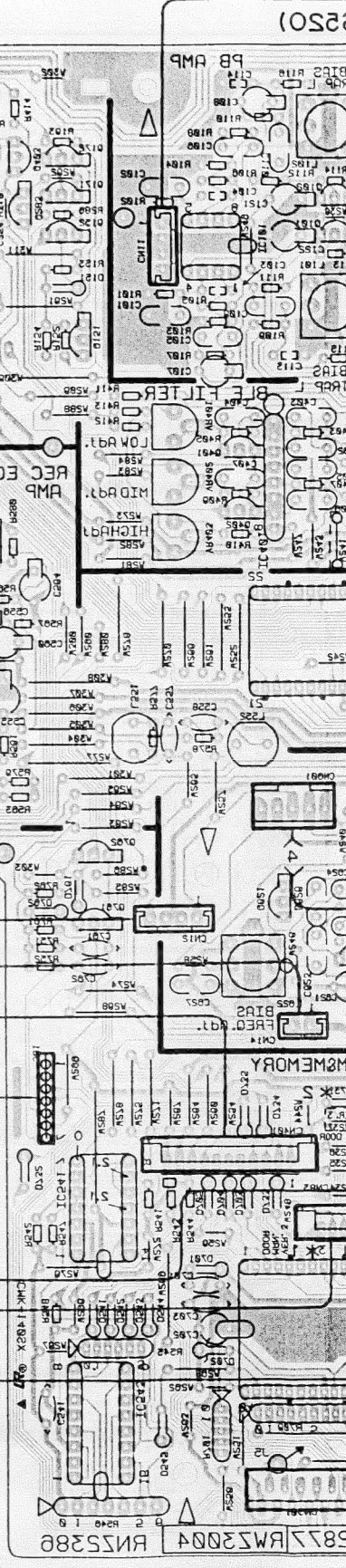

A  
B  
C  
D

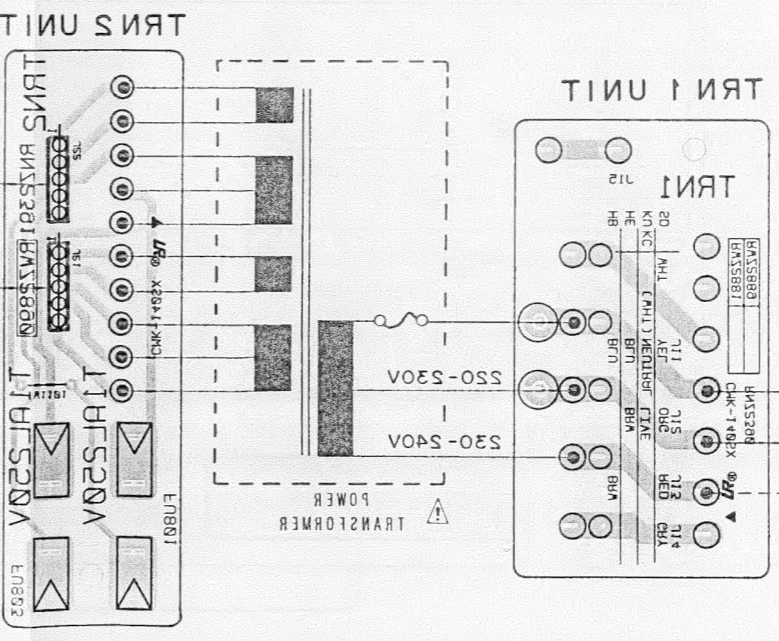
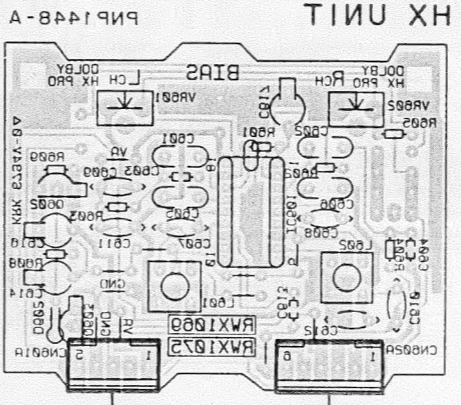
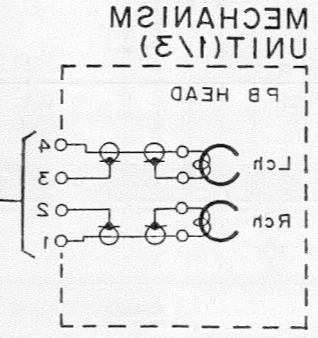
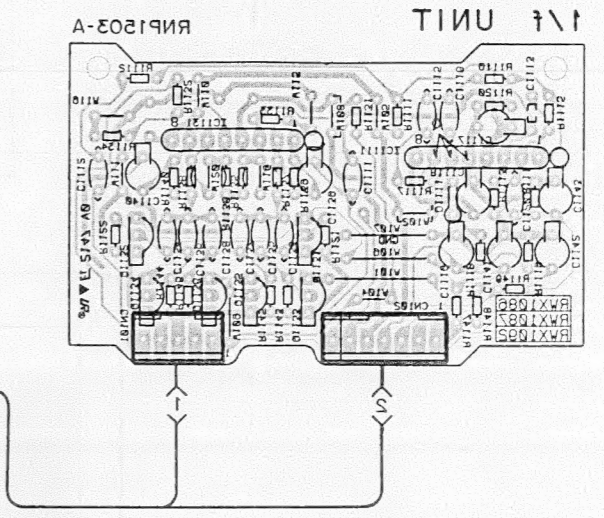

Line Voltage Selection  
 Line voltage can be changed with the following steps.  
 1. Disconnect the AC power cord.  
 2. Remove the top cover.  
 3. Change the position of the AC power cord as follows.

Terminal No. of TRN 1 UNIT	Voltage
1 1 2	230V-230V
1 1 3	230V-240V

Parts No	Description
AAX-193	220 V Label
AAX-192	240 V Label

4. Stick the line voltage label on the rear panel.

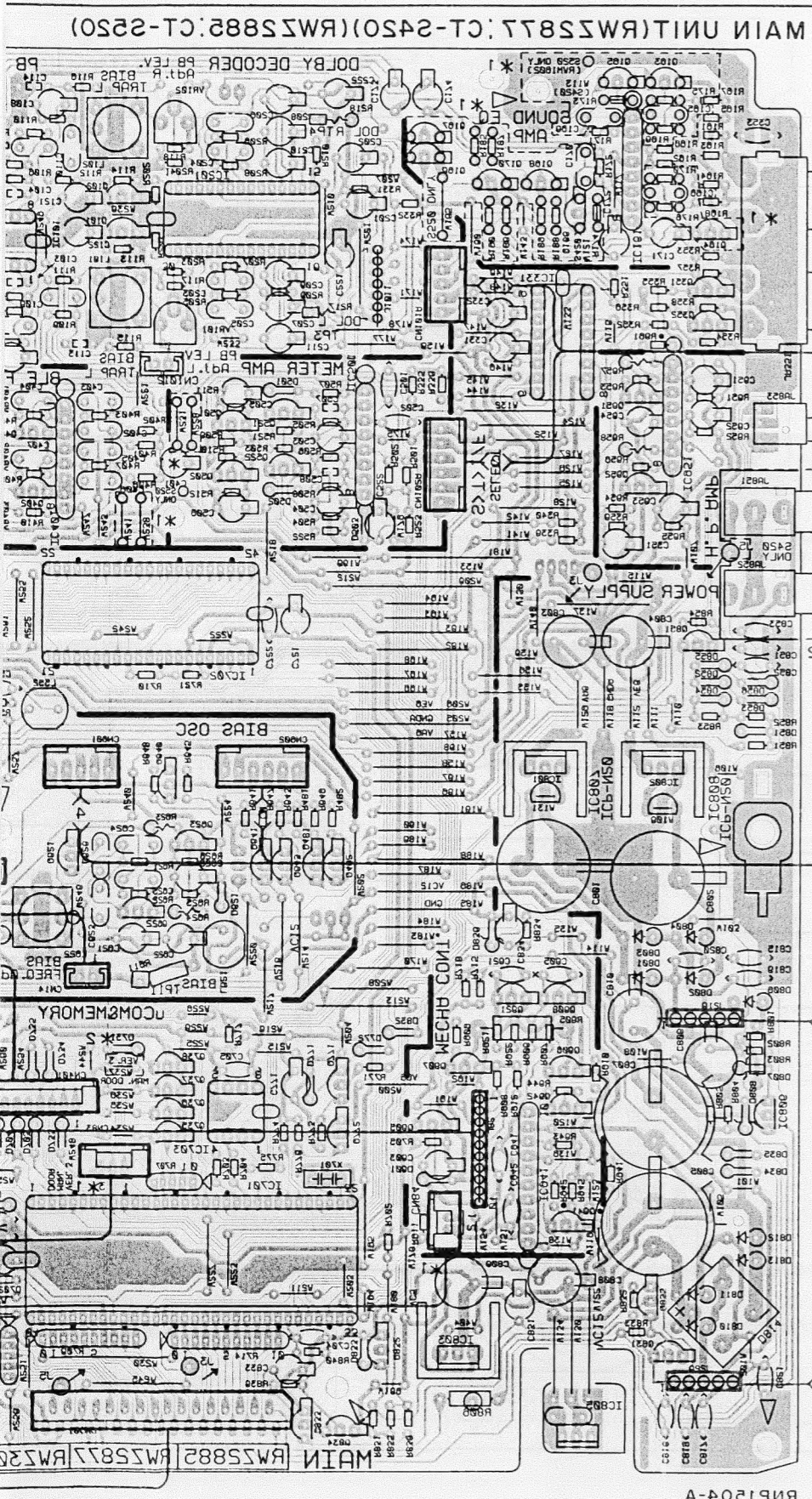
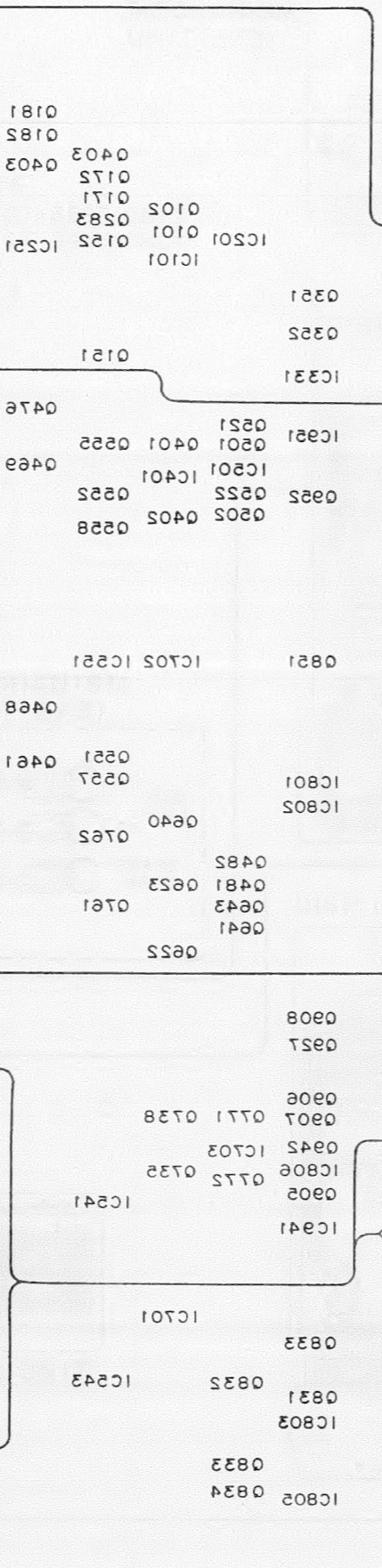
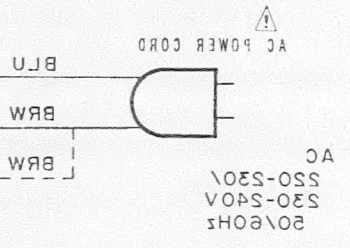

MAIN UNIT (RW2527, CT-2450) (RW2588, CT-2520)

RNP1504-A

• View from component side

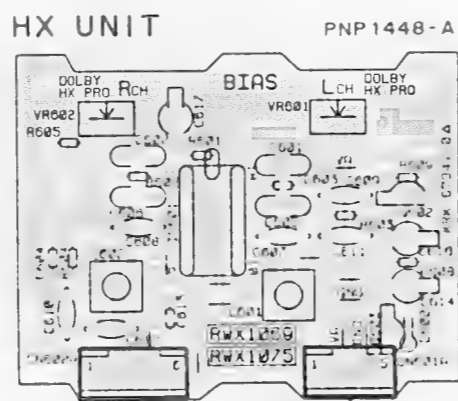
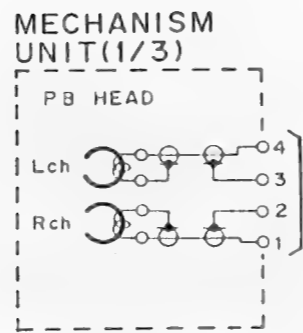
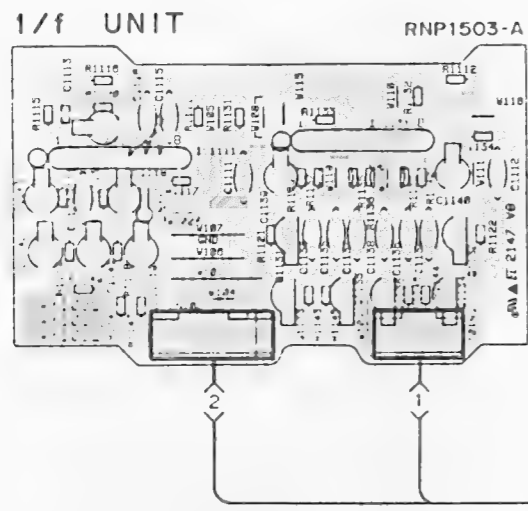

Line Voltage Selection

1. Disconnect the AC power cord.
2. Remove the Top cover
3. Change the position of the AC power cord as follows.

Voltage	Terminal No. of TRN 1 UNIT
220V-230V	J 1 2
230V-240V	J 1 3

4. Stick the line voltage label on the rear panel.

Parts No	Description
AAX-193	220 V label
AAX-192	240 V label

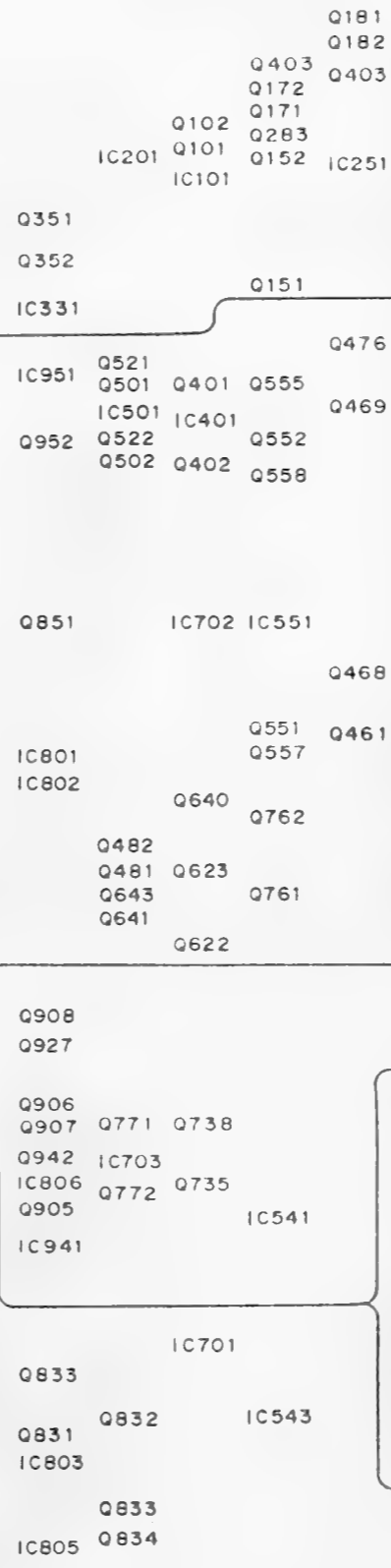
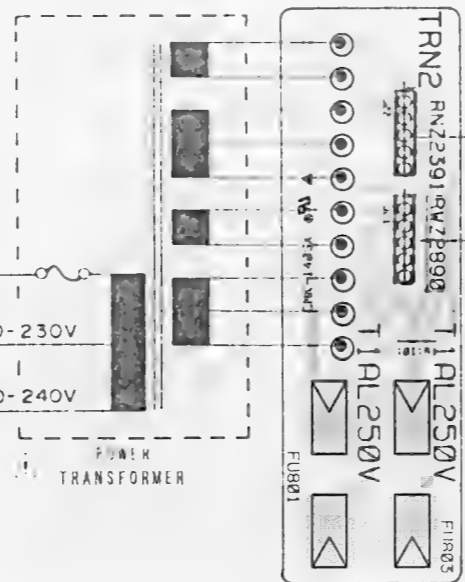
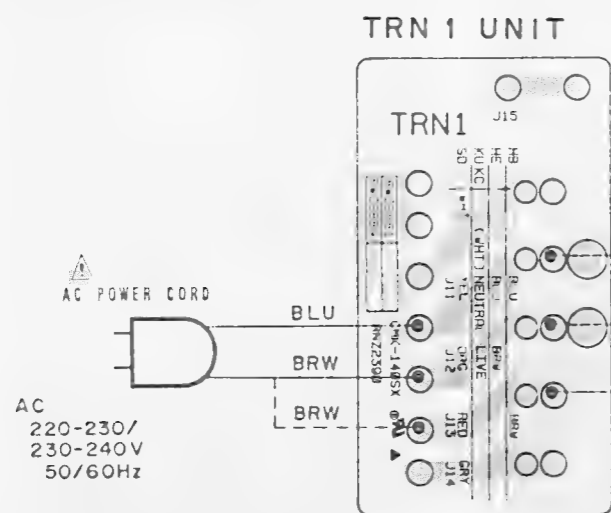

MAIN UNIT (RWZ2877:CT-S420) (RWZ2885:CT-S520)

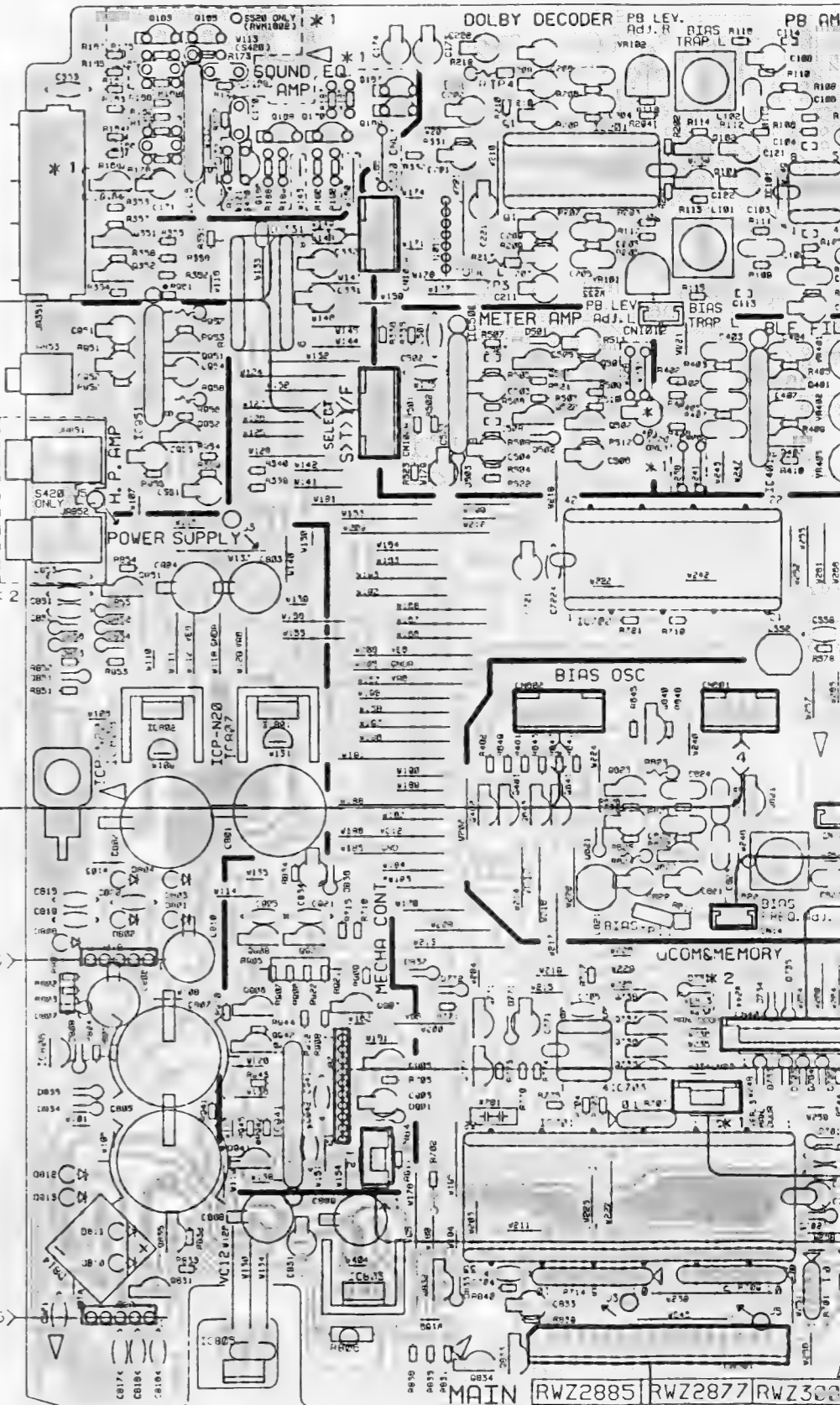

RNP1504-A

MAIN RWZ2885 RWZ2877 RWZ302

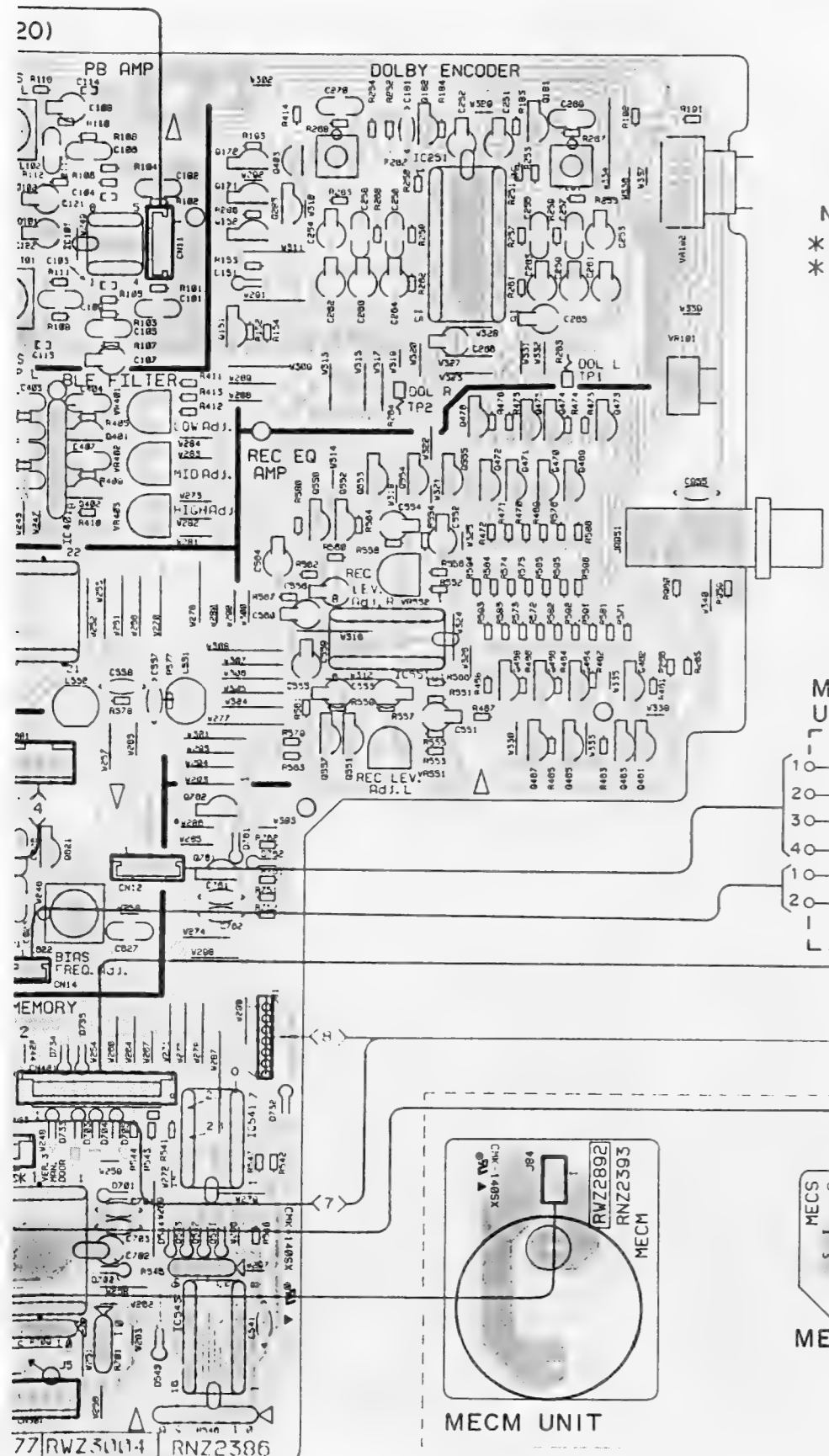

**MECHANISM UNIT(3/3)**

NOTE:  
 \* 1: CT-S520 ONLY.  
 \* 2: CT-S420 ONLY.

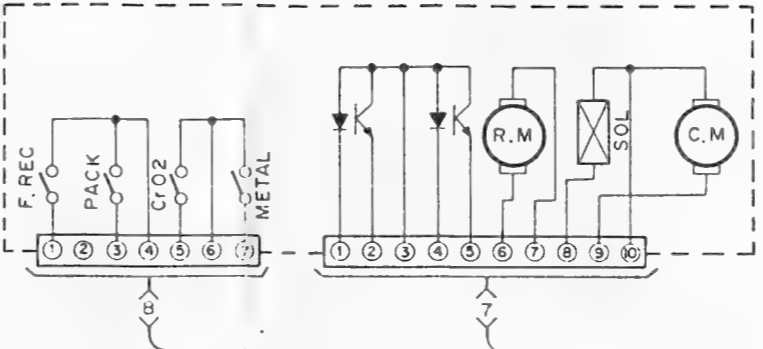

**MECHANISM UNIT(2/3)**

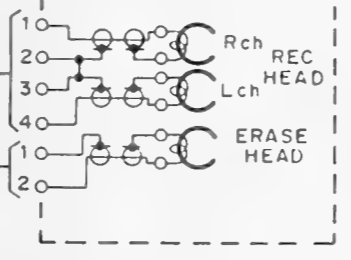

**OPSW UNIT(RWZ2888)**

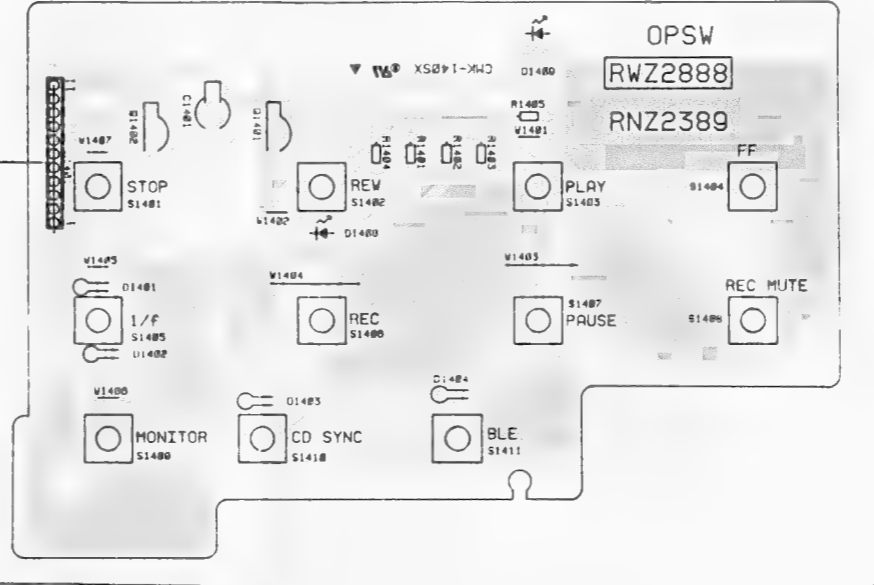

**DISP UNIT(RWZ2879:CT-S420)(RWZ2887:CT-S520)**

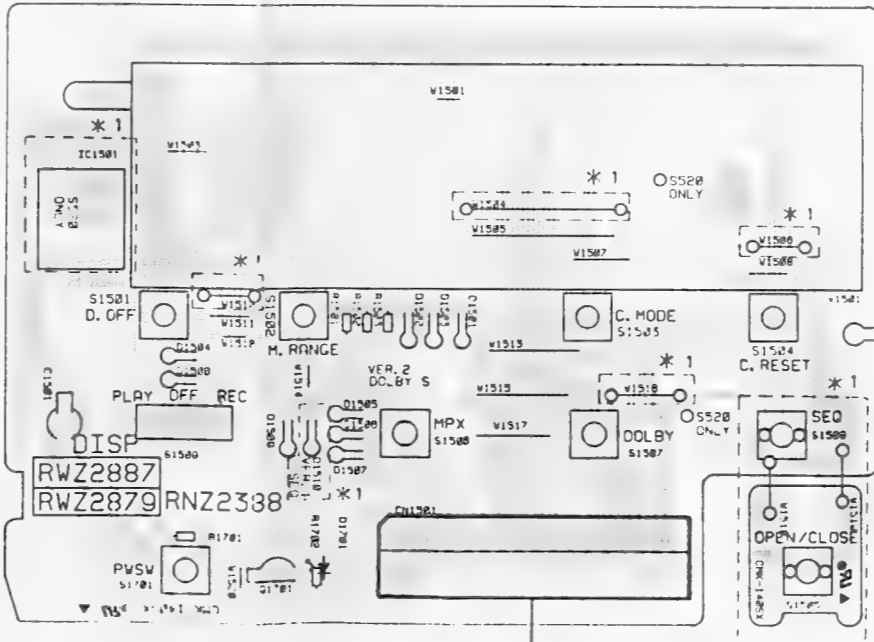

P.C.B. pattern diagram indication	Corresponding part symbol	Part name
		Transistor
		FET
		Diode
		Zener diode
		LED
		Varactor
		Tact switch
		Inductor
		Coil
		Transformer
		Filter
		Ceramic capacitor
		Mylar capacitor
		Styro capacitor
		Electrolytic capacitor (Non polarized)
		Electrolytic capacitor (Noiseless)
		Electrolytic capacitor (Polarized)
		Electrolytic capacitor (Polarized)
		Power capacitor
		Semi-fixed resistor
		Resistor array
		Resistor
		Resonator
		Thermistor

1. This P.C.B. connection diagram is viewed from the parts mounted side.  
 2. The parts which have been mounted on the board can be replaced with those shown with the corresponding wiring symbols listed in the above Table.  
 3. The capacitor terminal marked with shows negative terminal.  
 4. The diode marked with shows cathode side.  
 5. The transistor terminal marked with shows emitter.

A

B

C

D

# 6. SCHEMATIC DIAGRAM

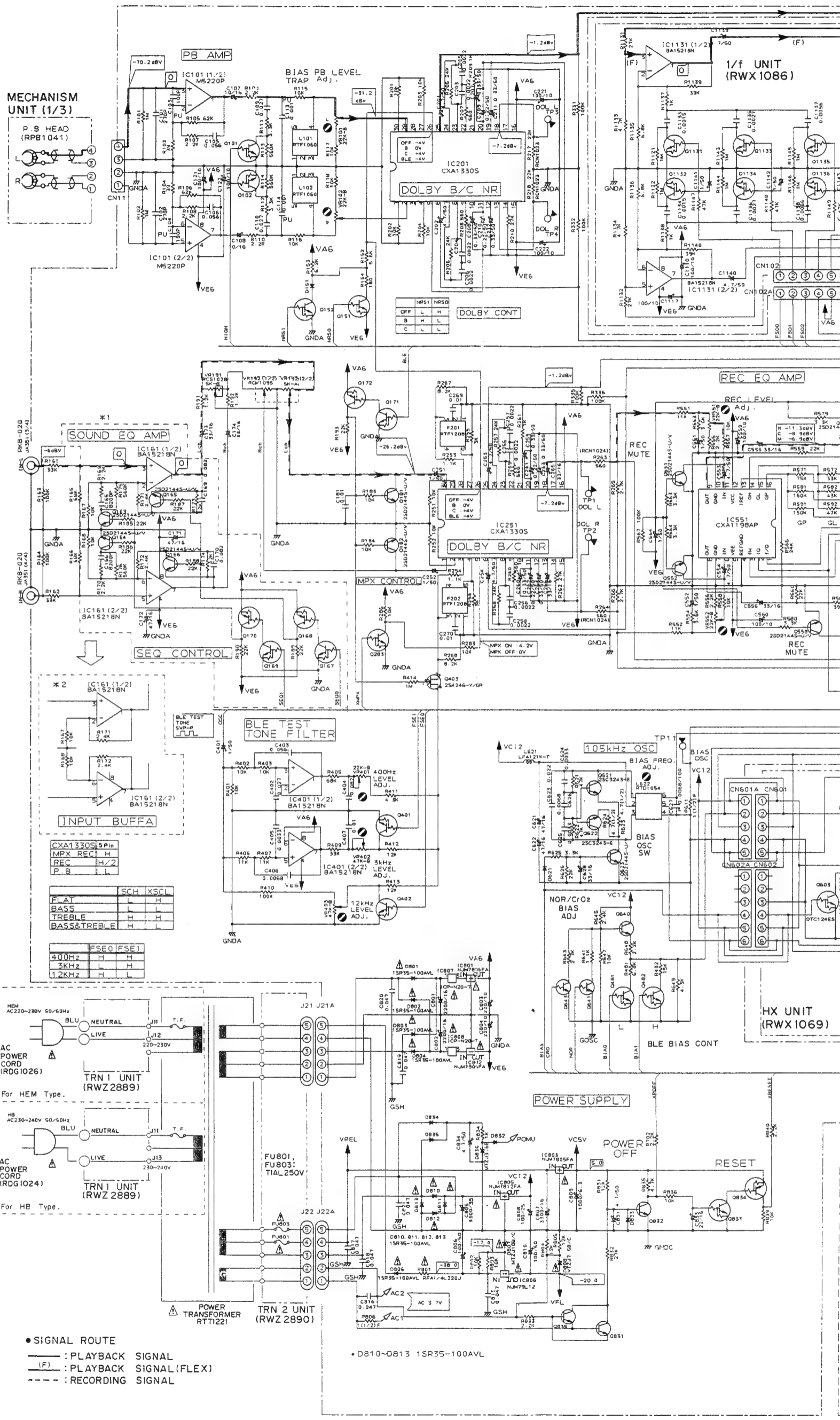

IC201, IC251 (CXA1330S)

Pin No.	Voltage [V]	Pin No.	Voltage [V]
1	0	16	6.0
2	0	17	0
3	0	18	0
4	0	19	-5.5
5	-6.0	20	-5.5
6	0	21	0
7	0	22	0
8	0	23	0
9	0	24	0
10	0	25	0
11	-5.5	26	0
12	-5.5	27	0
13	0	28	0
14	-4.7	29	0
15	-6.0	30	0

IC551 (CXA1198AP)

Pin No.	Voltage [V]	Pin No.	Voltage [V]
1	1.3	9	0
2	1.3	10	0
3	1.3	11	0
4	0	12	6.0
5	-6.0	13	1.3
6	0	14	1.3
7	0	15	1.3
8	0	16	1.3

IC941 (TA7288P)

Pin No.	Voltage [V]	Pin No.	Voltage [V]
1	0	6	0
2	0.5	7	12.0
3	0.5	8	6.6
4	0	9	12.7
5	0	10	0.5

IC601 (UPC1297CA)

Pin No.	Voltage [V]	Pin No.	Voltage [V]
1	4.4	10	1.7
2	0	11	0
3	4.4	12	0
4	0.6	13	0
5	0	14	0
6	0	15	0.6
7	0	16	4.4
8	0	17	0
9	0	18	12.0

CXA1330S Pin

MPX REC	H	L
FLAT	L	H
BASS	L	H
TREBLE	H	L
BASS & TREBLE	H	L

IFSE0 FSE1

400Hz	H	L
3KHz	L	H
12KHz	H	L

B

C

D

E

F

• SIGNAL ROUTE  
 — : PLAYBACK SIGNAL  
 (F) : PLAYBACK SIGNAL (FLEX)  
 - - - : RECORDING SIGNAL

• DB10-DB13 1SR35-100AVL

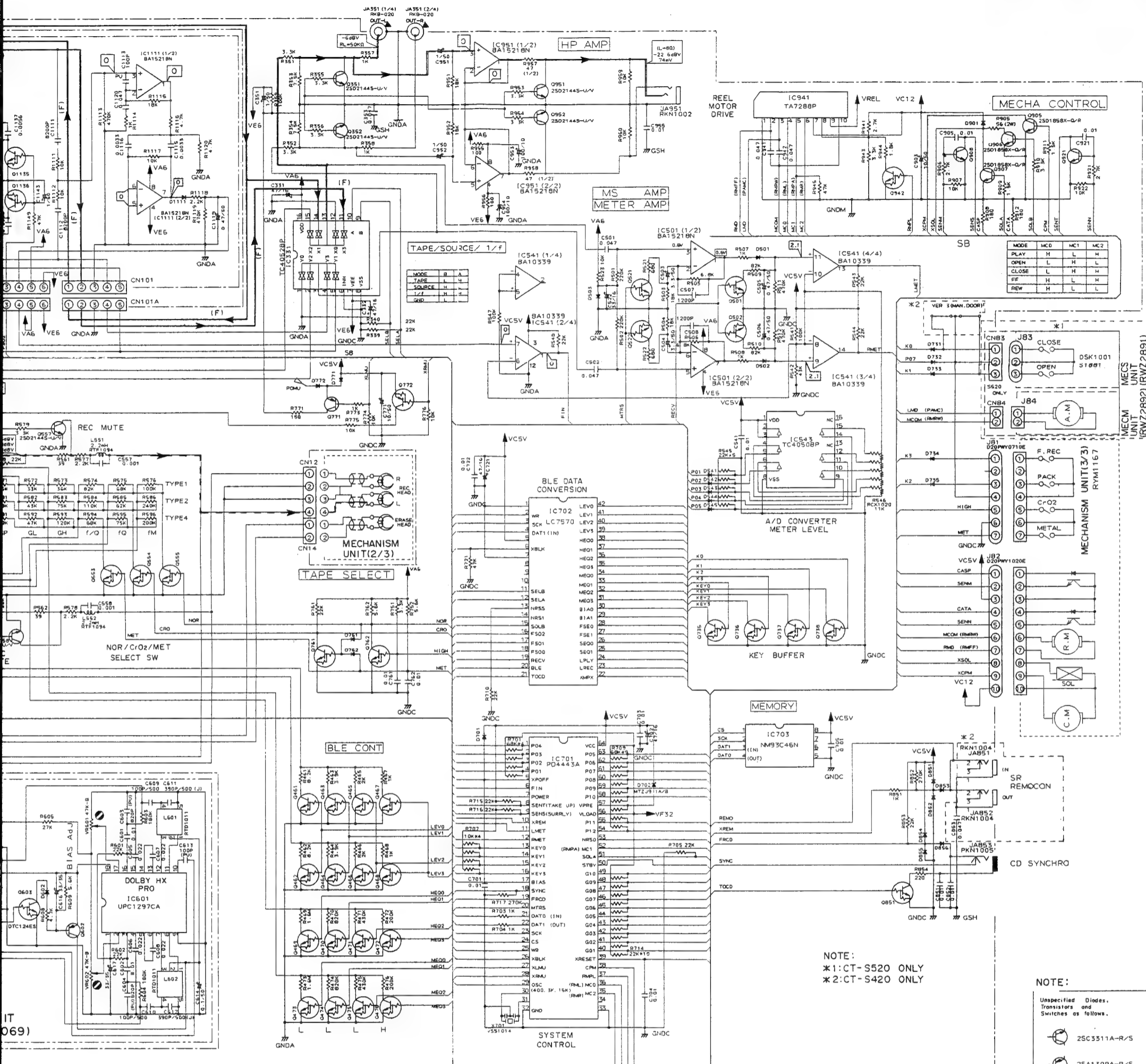

MODE	MC0	MC1	MC2
PLAY	H	L	H
OPEN	L	L	H
CLOSE	L	H	H
FF	H	L	H
REW	H	L	L

NOTE:  
 \*1:CT-S520 ONLY  
 \*2:CT-S420 ONLY

- NOTE:  
 Unspecified Diodes, Transistors and Switches as follows.
- 25C3511A-R/S
  - 25A1509A-R/S
  - DTC124ES
  - DTA124ES
  - DTC124TS
  - DTA124TS
  - 1SS254
  - S1401-S1411
  - S1505-S1508
  - RSG1030
  - S1501-S1504
  - RSG1034

MAIN UNIT  
 (RWZ2877:CT-S420)  
 (RWZ2885:CT-S520)

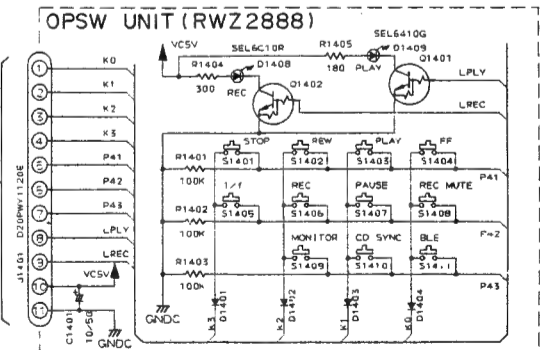

DISP UNIT  
 (RWZ2879:CT-S420)  
 (RWZ2887:CT-S520)

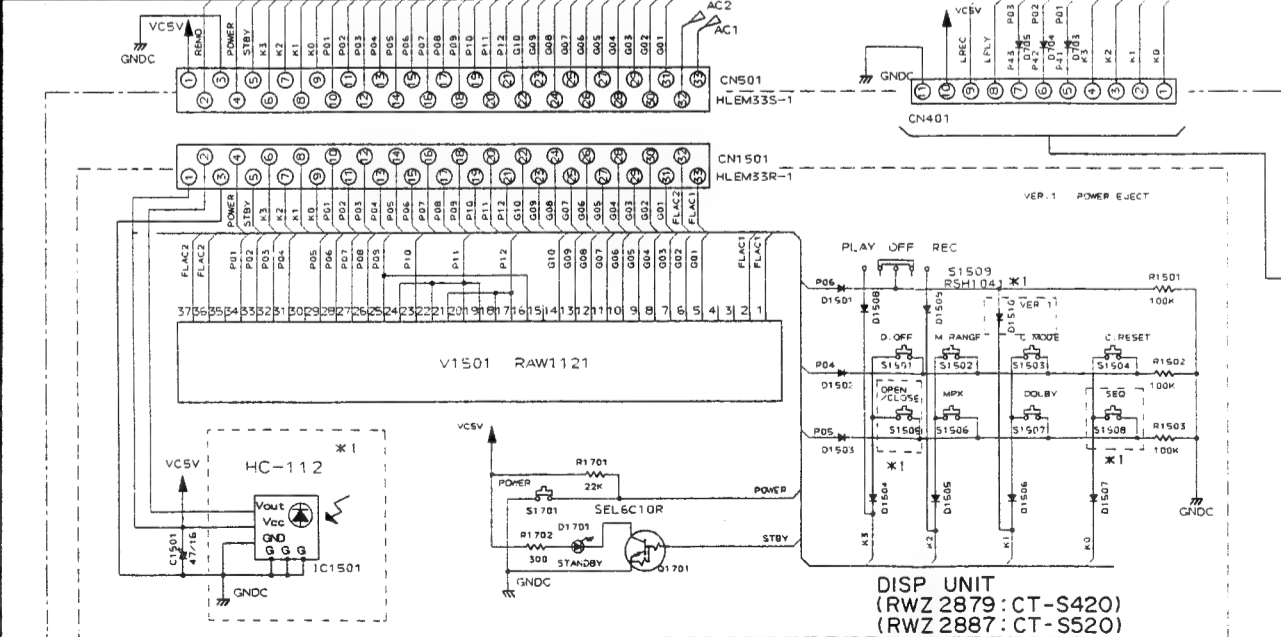

# CT-S520, CT-S420

## 7. PCB PARTS LIST

### NOTES:

- Parts marked by "NSP" are generally unavailable because they are not in our Master Spare Parts List.
- The  $\Delta$  mark found on some component parts indicates the importance of the safety factor of the part. Therefore, when replacing, be sure to use parts of identical designation.
- Parts marked by "C" are not always kept in stock. Their delivery time may be longer than usual or they may be unavailable.
- When ordering resistors, first convert resistance values into code form as shown in the following examples.

Ex.1 When there are 2 effective digits (any digit apart from 0), such as 560 ohm and 47k ohm (tolerance is shown by J=5%, and K=10%).

560  $\Omega$   $\rightarrow$  56  $\times$  10<sup>1</sup>  $\rightarrow$  561 ..... RD1/8PM  $\begin{matrix} 5 & 6 & 1 \\ | & | & | \\ \hline \end{matrix}$  J

47k  $\Omega$   $\rightarrow$  47  $\times$  10<sup>3</sup>  $\rightarrow$  473 ..... RD1/4PS  $\begin{matrix} 4 & 7 & 3 \\ | & | & | \\ \hline \end{matrix}$  J

0.5  $\Omega$   $\rightarrow$  0R5 ..... RN2H  $\begin{matrix} 0 & R & 5 \\ | & | & | \\ \hline \end{matrix}$  K

1  $\Omega$   $\rightarrow$  010 ..... RS1P  $\begin{matrix} 0 & 1 & 0 \\ | & | & | \\ \hline \end{matrix}$  K

Ex.2 When there are 3 effective digits (such as in high precision metal film resistors).

5.62k  $\Omega$   $\rightarrow$  562  $\times$  10<sup>1</sup>  $\rightarrow$  5621 ..... RN1/4PC  $\begin{matrix} 5 & 6 & 2 & 1 \\ | & | & | & | \\ \hline \end{matrix}$  F

Mark	No.	Description	Part No.	Mark	No.	Description	Part No.
------	-----	-------------	----------	------	-----	-------------	----------

### LIST OF ASSEMBLIES

#### • CT-S520

NSP	MOTHER UNIT	RWM1602
C	MAIN UNIT	RWZ2885
	HX UNIT	RWX1069
	1/f UNIT	RWX1086
	DISP UNIT	RWZ2887
NSP	OPSW UNIT	RWZ2888
NSP	TRN 2 UNIT	RWZ2890
NSP	MECS UNIT	RWZ2891
NSP	MECM UNIT	RWZ2892

#### • CT-S420

NSP	MOTHER UNIT	RWM1612
C	MAIN UNIT	RWZ2877
	HX UNIT	RWX1069
	1/f UNIT	RWX1086
	DISP UNIT	RWZ2879
NSP	OPSW UNIT	RWZ2888
NSP	TRN 2 UNIT	RWZ2890

### MAIN UNIT (For CT-S520)

#### SEMICONDUCTORS

	IC541	BA10339
	IC161, IC401, IC501, IC951	BA15218N
	IC551	CXA1198AP
	IC201, IC251	CXA1330S
$\Delta$	IC807, IC808	ICP-N20
	IC702	LC7570
	IC101	M5220P
$\Delta$	IC803	NJM7805FA
$\Delta$	IC801	NJM7806FA
$\Delta$	IC805	NJM7812FA
	IC802	NJM7906FA
$\Delta$	IC806	NJM79L12A
$\Delta$	IC703	NM93C46N
	IC701	PD4443A
	IC941	TA7288P
	IC543	TC4050BP
	IC331	TC4052BP
	Q771	2SA1309A

	Q621, Q622	2SC3243
	Q640, Q831, Q832, Q835, Q908, Q921	2SC3311A
	Q905-Q907	2SD1858X
	Q163-Q166, Q181, Q182, Q351, Q352,	2SD2144S
	Q551, Q552, Q557, Q558, Q623, Q951,	
	Q952	
	Q403	2SK246
	Q168, Q170, Q172, Q772, Q834	DTA124ES
	Q101, Q102, Q151, Q152, Q167, Q169,	DTC124ES
	Q171, Q283, Q401, Q402, Q461-Q476,	
	Q481, Q482, Q501, Q502, Q521, Q522,	
	Q553-Q555, Q735-Q738, Q761, Q762,	
	Q833, Q851, Q942	
	Q641, Q643	DTC124TS
$\Delta$	D801-D804, D806, D810-D813	1SR35-100AVL
	D151, D501-D503, D541-D545, D621,	1SS254
	D701, D703-D705, D731-D735, D761,	
	D762, D771, D772, D832-D835,	
	D851-D856, D901,	
$\Delta$	D807	MTZJ18B
$\Delta$	D836	MTZJ3.6B
$\Delta$	D808	MTZJ7.5B
	D702	MTZJ9.1A

#### COILS AND FILTERS

	L621	LFA121K
	L622	RTD1054
	L101, L102	RTF1060
	L551, L552	RTF1094
	F201, F202	RTF1208

#### CAPACITORS

	C351, C401, C551, C552, C564	CEAS010M50
	C771, C903	CEAS100M50
	C121, C122, C221, C222, C559, C560,	CEAS101M10
	C953, C954	
	C808	CEAS101M25
	C806, C810	CEAS101M50
	C809	CEAS102M6R3
	C833	CEAS220M16
	C628	CEAS330M16
	C807	CEAS332M16

Mark	No.	Description	Part No.
	C805		CEAS332M25
	C503, C504		CEAS3R3M50
	C171, C172, C331, C332, C522, C621,		CEAS470M16
	C622, C702, C721		
	C831, C834		CEAS4R7M50
	C209, C210, C261, C262		CEASR22M50
	C207, C208, C211, C212, C259, C260,		CEASR33M50
	C263, C264		
	C505, C506		CEASR47M50
	C803, C804		CENA221M10
	C801, C802		CENA222M16
	C269, C270, C407		CFTXA103J50
	C203-C206, C255-C258		CFTXA222J50
	C405, C624, C625		CFTXA332J50
	C403		CFTXA563J50
	C406, C626		CFTXA682J50
	C165, C166		CFTXA822J50
	C623		CFTYA223J50
	C109, C110, C402		CFTYA273J50
	C105, C106		CFTYA563J50
	C169, C170, C404		CFTYA823J50
	C501, C502		CGCYX473K25
	C557, C558		CKCYB102K50
	C507, C508		CKCYB122K50
	C181, C541, C701, C703-C705, C722,		CKCYF103Z50
	C761, C762, C851, C852, C905, C921,		
	C955		
	C353, C815-C821, C941, C942		CKCYF473Z50
	C103, C104		CKPUYB101K50
	C113, C914		CKPUYB102K50
	C101, C102		CQPA271J100
	C627		CQPA682J100

### MAIN UNIT (For CT-S420)

RWZ2877 (for CT-S420) and RWZ2885 (for CT-S520) for the following:

Mark	Symbol & Description	Part No.
	Q163 - Q166	2SD1858X
	Q167, Q169	DTA124ES
	Q168, Q170	DTA124ES
	C165, C166	CFTXA822J50
	C169, C170	CFTYA223J50
	C853	
	R169, R170	RD103J50
	R173, R174	RD103J50
	R175, R176	RD103J50
	R185 - R190	RD103J50
	JA851, JA852	

Note: (Type 6)  
 1. When ordering service parts, be sure to refer to "PARTS LIST of EXPLODED VIEWS" or "PCB PARTS LIST".  
 2. Since these are basic circuits, some parts of them or the values of some components may be changed for improvement.  
 3. RESISTORS:  
 Unit: k:K2, M:M2, or Ω unless otherwise noted.  
 Rated power: 1/4W, 1/6W, 1/8W, 1/10W unless otherwise noted.  
 Tolerance: (F): ±1%, (G): ±2%, (K): ±10%, (M): ±20% or ±5% unless otherwise noted.  
 4. CAPACITORS:  
 Unit: p:F or μF unless otherwise noted.  
 Ratings: capacitor (μF)/voltage (V) unless otherwise noted.  
 Rated voltage: 50V except for electrolytic capacitors.  
 5. COILS:  
 Unit: m:mH or μH unless otherwise noted.  
 6. VOLTAGE AND CURRENT:  
 Unit: DC voltage (V) in STOP mode unless otherwise noted.  
 ⊕ mA or - mA: DC current in STOP mode unless otherwise noted.  
 7. OTHERS:  
 ● : Signal route.  
 ⊙ : Adjusting point.  
 ● (Red) : Measurement point.  
 ● The △ mark found on some component parts indicates the importance of the safety factor of the parts. Therefore, when replacing, be sure to use parts of identical designation.

8. SWITCHES (Underline indicates switch position):  
 S1401 : ■  
 S1402 : ►►  
 S1403 : ►  
 S1404 : ◄  
 S1405 : FLEX (1/↑)  
 S1406 : REC  
 S1407 : ■  
 S1408 : REC MUTE  
 S1409 : MONITOR  
 S1410 : CD SYNCHRO  
 S1411 : AUTO BLE  
 DISP UNIT  
 S1501 : DISP OFF  
 S1502 : METER RANGE  
 S1503 : COUNTER MODE  
 S1504 : COUNTER RESET  
 S1505 : OPEN/CLOSE  
 S1506 : MPX FILTER  
 S1507 : DOLBY NR OFF/B/C  
 S1508 : SOUND EQ  
 S1509 : TIMER (REC - OFF - PLAY)  
 S1701 : POWER

(For SCHEMATIC DIAGRAM)

Mark No.	Description	Part No.
C251, C252, C951, C952 (C=1, V(DC)=50)		RCH1079
C107, C108 (C=10, V(DC)=50)		RCH1080
C201, C202, C253, C254, C553, C554 (4.7, V(DC)=50)		RCH1090
C173, C174, C265, C266, C555, C556 (C=33, V(DC)=16)		RCH1091
<b>RESISTORS</b>		
R714 (22K)		RA10T223J
R707 (10K)		RA4T103J
R701 (68K)		RA4T683J
R545 (22K)		RA5T223J
R709 (68K)		RA9T683J
R623, R624 (4.7Ω)		RCN1022
R217, R218 (22K)		RCN1023
R263, R264 (560Ω)		RCN1024
R957, R958 (47Ω)		RCN1054
R546 (11K/22K)		RCX1020
R611, R806		RD1/2LF010J
R801 (22Ω)		RFA1/4L220J
R905 (56Ω)		RS2LMF560J
VR101, VR102, VR401, VR551, VR552 (22K)		RCP1046
VR402, VR403 (47K)		RCP1047
R=47K, W= 0.1, MAKER=		
VR191 (BALANCE VR)		RCS1028
VR192 REC VR)		RCV1095
OTHER RESISTORS		RD1/6PM□□□J
<b>OTHERS</b>		
CN501 CONNECTOR (33P)		HLEM33S-1
JA853 MINI JACK		PKN1005
JA351 PIN JACK (4P)		RKB-020
JA951 HEADPHONE JACK		RKN1002
X701 CERAMIC RESONATOR (4.19MHz)		VSS1014

Mark No.	Description	Part No.
<b>HX UNIT</b>		
<b>SEMICONDUCTORS</b>		
IC601		UPC1297CA
Q602		2SA1309A
Q603		DTC124ES
D602		ISS254
<b>COILS</b>		
L601, L602 (L=4.6MHz, Q=75, F=105KHz)		RTD1011
<b>CAPACITORS</b>		
C609, C610		CCCSL101K500
C616, C617		CEAS330M35
C614		CEASR10M50
C601, C602		CFTXA103J50
C605, C606		CFTXA223J50
C607, C608		CGCYX223K25
C613		CKPUYB101K50
C603, C604		CKPUYB821K50
C611, C612 (C=390P, V(DC)=500)		RCG1004
<b>RESISTORS</b>		
VR601, VR602		VRTB6HS473
OTHER RESISTORS		RD1/6PM□□□J
<b>1/f UNIT</b>		
<b>SEMICONDUCTORS</b>		
IC1111, IC1131		BA15218N
Q1131-Q1136		DTC124ES
D1111		ISS254
<b>CAPACITORS</b>		
C1141-C1143		CEAS010M50
C1117, C1118		CEAS101M10
C1139, C1140		CEAS4R7M50
C1119		CEASR47M50
C1133, C1134		CGCYX152K25
C1135, C1136		CGCYX272K25
C1115, C1116		CGCYX332K25
C1120		CGCYX473K25
C1137, C1138		CGCYX562K25
C1111, C1112		CGCYX822K25
C1113		CKPUYB101K50
<b>RESISTORS</b>		
ALL RESISTORS		RD1/6PM□□□J

Mark No.	Description	Part No.
<b>CAPACITORS</b>		
C1501		CEAS470M16
<b>RESISTORS</b>		
ALL RESISTORS		RD1/6PM□□□J
<b>OTHERS</b>		
CN1501 CONNECTOR (33P)		HLEM33R-1
V1501 FL INDICATOR TUBE		RAW1121
REMOTE CONTROL SENSOR (CT-S520 only)		HC-112
<b>OPSW UNIT</b>		
<b>SEMICONDUCTORS</b>		
Q1401, Q1402		DTC124ES
D1401-D1404		ISS254
D1409		SEL6410G
D1408		SEL6C10R
<b>SWITCHES</b>		
S1401-S1411		RSG1030
<b>CAPACITORS</b>		
C1401		CEAS100M50
<b>RESISTORS</b>		
ALL RESISTORS		RD1/6PM□□□J
<b>TRN 2 UNIT</b>		
TRN 2 unit has no service part.		
<b>MECS UNIT</b>		
<b>SWITCHES</b>		
S1881		VSK1011
<b>MECM UNIT</b>		
MECM unit has no service part.		

CT-S520) have the same construction except

Part No.		Remarks
RWZ2885	RWZ2877	
2SD2144S	.....	
DTC124ES	.....	
DTA124ES	.....	
CFTXA822J50	.....	
CFTYA823J50	.....	
.....	CKCYF473Z50	
RD1/6PM222J	.....	
RD1/6PM123J	.....	
RD1/6PM564J	.....	
RD1/6PM223J	.....	
.....	RKN1004	







Mark No.	Description	Part No.
<b>DISP UNIT (For CT-S520 and CT-S420)</b>		
<b>SEMICONDUCTORS</b>		
Q1701		DTC124ES
D1501-D1509		ISS254
D1510(CT-S520 only)		ISS254
D1701		SEL6C10R
<b>SWITCHES</b>		
S1505, S1508(CT-S520 only)		RSG1030
S1506, 1507, S1701		RSG1030
S1501-S1504		RSG1034
S1509		RSH1041



(For SCHEMATIC DIAGRAM)





Note:

(Type 6)

1. When ordering service parts, be sure to refer to "PARTS LIST of EXPLODED VIEWS" or "PCB PARTS LIST".
2. Since these are basic circuits, some parts of them or the values of some components may be changed for improvement.
3. RESISTORS:  
Unit: k:k $\Omega$ , M:M $\Omega$ , or  $\Omega$  unless otherwise noted.  
Rated power: 1/4W, 1/6W, 1/8W, 1/10W unless otherwise noted.  
Tolerance: (F):  $\pm 1\%$ , (G):  $\pm 2\%$ , (K):  $\pm 10\%$ , (M):  $\pm 20\%$  or  $\pm 5\%$  unless otherwise noted.
4. CAPACITORS:  
Unit: p:pF or  $\mu$ F unless otherwise noted.  
Ratings: capacitor ( $\mu$ F)/ voltage (V) unless otherwise noted.  
Rated voltage: 50V except for electrolytic capacitors.
5. COILS:  
Unit: m:mH or  $\mu$ H unless otherwise noted.
6. VOLTAGE AND CURRENT:  
 : DC voltage (V) in STOP mode unless otherwise noted.  
 mA or -mA: DC current in STOP mode unless otherwise noted.
7. OTHERS:
  -  : Signal route.
  -  : Adjusting point.
  -  (Red) : Measurement point.
  - The  mark found on some component parts indicates the importance of the safety factor of the parts. Therefore, when replacing, be sure to use parts of identical designation.

8. SWITCHES (Underline indicates switch position):

OPSW UNIT

- S1401 : 
- S1402 : 
- S1403 : 
- S1404 : 
- S1405 : FLEX (l/f)
- S1406 : REC
- S1407 : 
- S1408 : REC MUTE
- S1409 : MONITOR
- S1410 : CD SYNCHRO
- S1411 : AUTO BLE

DISP UNIT

- S1501 : DISP OFF
- S1502 : METER RANGE
- S1503 : COUNTER MODE
- S1504 : COUNTER RESET
- S1505 : OPEN/CLOSE
- S1506 : MPX FILTER
- S1507 : DOLBY NR OFF/B/C
- S1508 : SOUND EQ
- S1509 : TIMER (REC - OFF - PLAY)

S1701 : POWER

## 8. ADJUSTMENTS

### 8.1 MECHANICAL ADJUSTMENT

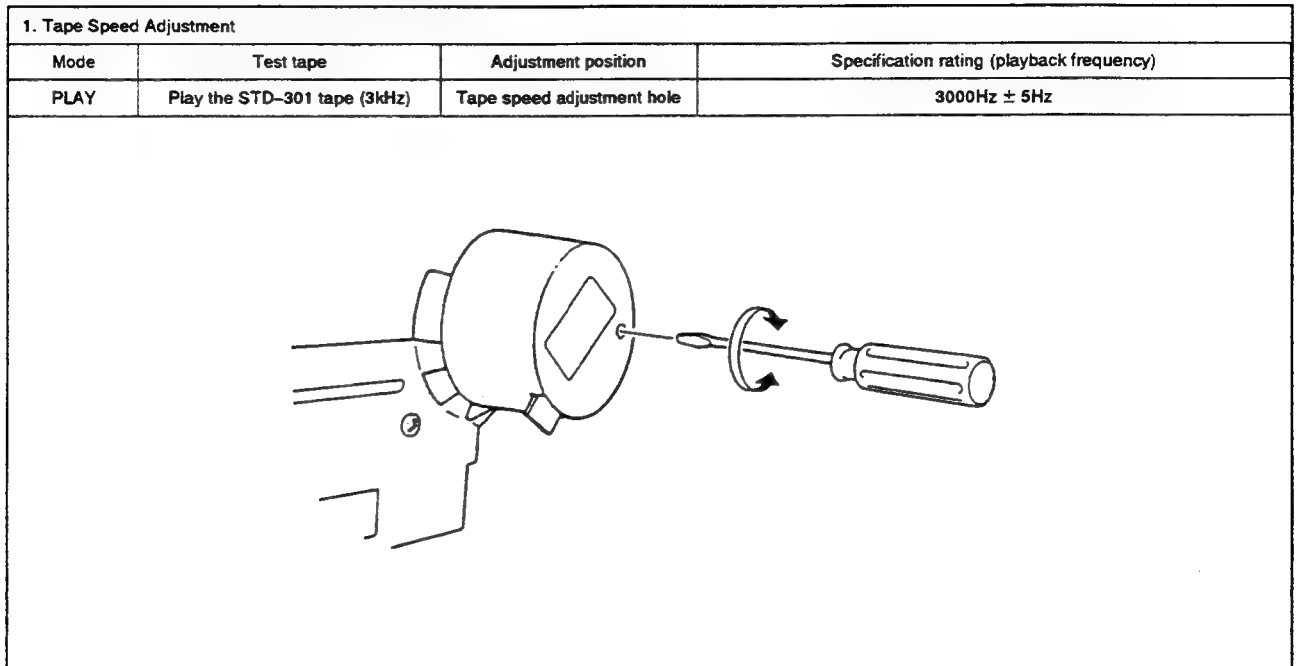

Fig. 8-1 Tape speed adjustment

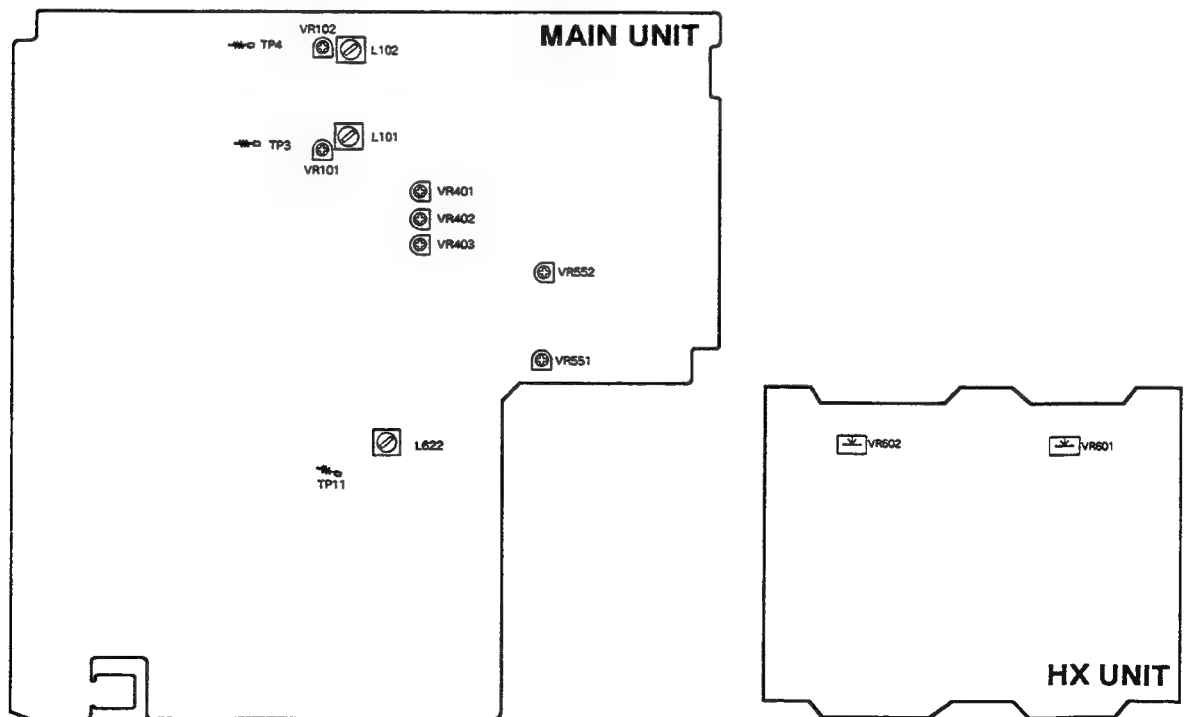

Fig. 8-2 Adjusting points

## 8.2 ELECTRICAL ADJUSTMENTS

### Adjustment Conditions

1. The mechanical adjustments must be completed first.
2. The head must be cleaned and demagnetized.
3. Turn power on allow the deck to warm up for at least a few minutes before commencing any electrical adjustments.
4. The reference signal is 0 dBV=1 Vrms.
5. Connect a 50 kΩ (or between 47k to 52 kΩ ) load resistance to the OUTPUT terminals.
6. Unless otherwise specified, the switches listed below are left in the positions indicated.

DOLBY NR : OFF  
 TAPE SELECTOR : NORM

### Test Tapes

STD-331E : Playback adjustments  
 (See Fig. 8-3)  
 STD-631 : NORMAL blank tape  
 STD-621 : CrO<sub>2</sub> blank tape  
 STD-610 : METAL blank tape

\* As the reference recording level is 250 nwb/m for STD-331E, the recording level will be higher by 4 dB for STD-331B (160 nwb/m). When adjusting, pay carefull attention to the type of tape used.

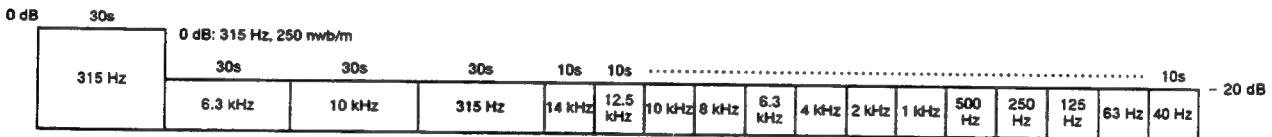

Fig. 8-3 Constants of the test tape STD-331E

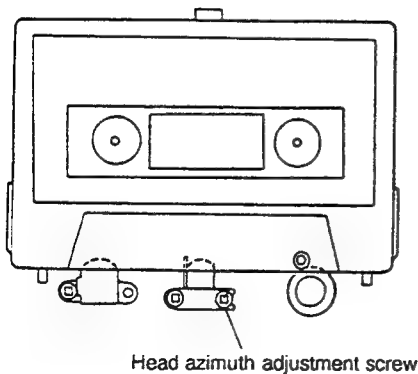

Fig. 8-4 Head azimuth adjustment

### List of Adjustments

#### Playback sections

1. Head azimuth adjustment.
2. Playback level adjustment.

#### Recording sections

1. Bias oscillator adjustment.
2. Bias trap adjustment.
3. Recording bias adjustment.
4. Recording level adjustment.
5. AUTO BLE adjustment

NOTE: This unit has an automatic tape selection feature.

*HX Pro headroom extension originated by Bang & Olufsen and manufactured under license from Dolby Laboratories Licensing Corporation. "DOLBY", the double-D symbol  $\square$ , and "HX PRO" are trademarks of Doldy Laboratories Licensing Corporation.*

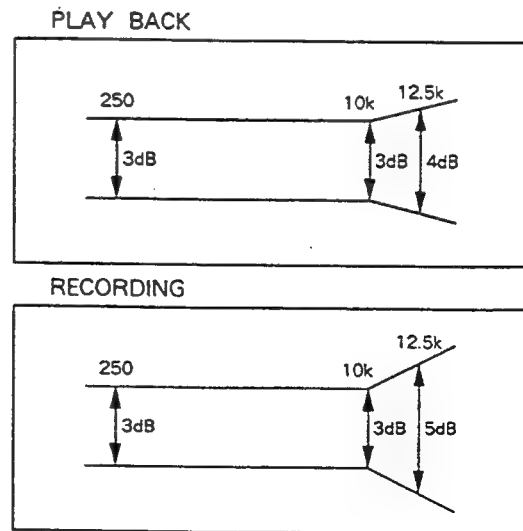

Fig. 8-5 Frequency response zone

## PLAYBACK SECTION

### 1. Head Azimuth Adjustment

- Turn VR101, 102 to mechanical center positions.

No.	Mode	Input signal & test tape	Adjustment location	Measuring location	Adjustment value	Remarks	
1.	PLAY	Play the 10 kHz/-20 dB section of STD-331E test tape.	Head azimuth adjustment screw. (See Fig. 8-4)	LINE OUT	Maximum playback signal level.		
2.	STOP	Lock the screw with screw lock after completing adjustment.					

### 2. Playback Level Adjustment

- This adjustment determines the DOLBY NR level, and must be performed with great care.

No.	Mode	Input signal & test tape	Adjustment location	Measuring location	Adjustment value	Remarks
1.	PLAY	Play the 315 Hz/0 dB section of the STD-331E test tape.	Deck VR101 (Lch) VR102 (Rch)	TP. 3 (Lch) TP. 4 (Rch)	-6.7 dBV	This adjustment must be performed accurately for proper Dolby lever setting.

## RECORDING SECTION

### 1. Bias Oscillator Adjustment

No.	Mode	Input signal & test tape	Adjustment location	Measuring location	Adjustment value	Remarks
1.	REC	Load the STD-610 test tape with no input signal.	Deck L622	TP. 11	105 kHz $\pm$ 0.3 kHz	

### 2. Bias Trap Adjustment

No.	Mode	Input signal & test tape	Adjustment location	Measuring location	Adjustment value	Remarks
1.	REC	Load the STD-610 test tape with no input signal.	Deck L101 (Lch) L102 (Rch)	LINE OUT	Minimum output	

### 3. Recording Bias Adjustment

- After the adjustment, caution should be exercised so as not to become under bias by checking the distortion rate.



No.	Mode	Input signal & test tape	Adjustment location	Measuring location	Adjustment value	Remarks
1.	REC/ PAUSE	Apply a 315 Hz and 10 kHz signal to the line input terminals, load the STD-631 test tape.	REC level control volume	LINE OUT	- 26 dBV	
2.	REC	Record the above signal onto the STD-631 test tape, and playback	Deck VR601 (Lch) VR602 (Rch)		Repeatedly record, playback and adjust so that the playback level of 10 kHz signal becomes 0 dB $\pm$ 0.5 dB when compared with the 315 Hz signal.	

## 4. Recording Level Adjustment

No.	Mode	Input signal & test tape	Adjustment location		Measuring location	Adjustment value	Remarks
1.	REC/ PAUSE	Apply a 315 Hz signal to the line input terminals, load the STD-631 test tape.	REC level control volume		LINE OUT	-10.0 dBV	
2.	REC/ PLAY	Record the above signal onto the STD-631 test tape, and playback.	Deck	VR551 (Lch) VR552 (Rch)	TP. 3 (Lch) TP. 4 (Rch)	Repeatedly record, playback and adjust so that the playback signal level becomes -11.2 dBV.	
3.	REC/ PLAY	Record the above signal onto the STD-621 test tape, and playback.	Check		TP. 3 (Lch) TP. 4 (Rch)	-11.2 dBV ± 1.5 dB	
4.	REC/ PLAY	Record the above signal onto the STD-610 test tape, and playback.	Check		TP. 3 (Lch) TP. 4 (Rch)	-11.2 dBV ± 1.5 dB	

## 5. AUTO BLE Adjustment

- BLE adjustment should be performed after all other adjustments are completed.
- This adjustment should be performed in the test mode.
- Entering the Test Mode.  
Turn on the power, and after more than 4 seconds, press the "COUNTER RESET" button, "COUNTER MODE" button and **|||** (PAUSE) button simultaneously.
- Releasing the Test Mode.  
Press the "COUNTER RESET" button.

No.	Mode	Input signal & test tape	Adjustment location	Measuring location	Adjustment value	Remarks
1.		Set to test mode.	-	-	-	
2.		Press the AUTO BLE key on the front panel.	VR401	Level meter Rch	Adjust the Lch segment which is lit until Rch is not lighting up.  Lch  Rch  (■ : light up □ : not light up)	400 Hz adjustment (FL indication 1)
3.		Press the AUTO BLE key on the front panel.	VR402			3 kHz adjustment (FL indication 2)
4.		Press the AUTO BLE key on the front panel.	VR403			15 kHz adjustment (FL indication 3)

## 9. IC INFORMATION

- The information shown in the list is basic information and may not correspond exactly to that shown in the schematic diagrams.

### 1. PD4443A (IC701) System Control (CPU)

#### ● Pin Function

Pin No.	Pin Name	Functions
1	P04	FL segment output (*1) A/D 5-bit level scan output (*2) Key scan output (*3)
2	P03	
3	P02	
4	P01	
5	XPOFF	POWER OFF detection $\bar{L}$ (L: EDGE)
6	FIN	Level scan input for the 1/f high frequency level
7	POWER	POWER KEY input detection $\bar{L}$ (L: EDGE)
8	SENT	TAKE-UP side reel sense input. For the auto stop electronic counter
9	SENS	Supply side reel sense input. For measuring the remain counter.
10	XREM	Remote control unit input
11	LMET	Lch level scan input
12	RMET	Rch level scan input
13	KEY0	4-bit key scan input (L: EDGE)
14	KEY1	
15	KEY2	
16	KEY3	
17	BIAS	Bias oscillation drive. H: ON
18	SYNC	CD-SYNCHRO code in detection. L: IN
19	FRCD	CONT to CD (for CD-SYNCHRO) INPUT
20	MTRS	Meter amplifier gain selection.
21	DAT0	Data input from the memory IC (NM93C46N).
22	DAT1	Data output to NM93C46N and LC7570.
23	SCK	Clock for communicating with NM93C46N and LC7570
24	CS	Chip select for communicating with NM93C46N
25	WR	Data latch for communicating with LC7570
26	XBLK	L CONT of all outputs of LC7570
27	XLMU	LINE MUTE. L: ON
28	XRMU	REC MUTE. L: ON
29	OSC	TEST signal output for the auto BLE (400 Hz, 3 kHz, 15 kHz)
30	—	Clock input for the CPU (4.19 MHz)
31	—	
32	GND	To GNDC

Pin No.	Pin Name	Function
33	—	To GNDC
34	—	Non connection
35	MC2	Motor CONTs for the door and reel
36	MC0	
37	RMPL	Reel motor PLAY torque selection. H: ON
38	CPM	Mechanism capstan motor driving. H: ON
39	XRESET	For resetting the CPU. L: Resetting
40	G01	Output for the FL grid
41	G02	
42	G03	
43	G04	
44	G05	
45	G06	
46	G07	
47	G08	
48	G09	
49	G10	
50	STBY	LED driving for the POWER STANDBY. H: ON
51	SDLA	Solenoid driving for the mechanism. H: ON
52	MC1	Motor CONTs for the door and reel
53	NRS0	1 bit of the 2-bit Dolby NR selection
54	P12	FL segment (*1)
55	P11	
56	VLOAD	For FL. V <sub>F</sub>
57	V <sub>PRE</sub>	CPU internal FL output buffer power supply (Approx. -4V)
58	P10	FL segment output (*1)
59	P09	
60	P08	FL segment output (*1) Key scan output (*3)
61	P07	
62	P06	FL segment output (*1) Level scan (*2) Key scan output (*3)
63	P05	
64	Vcc	To Vcc +5V

\*1: To the FL

\*2: To the anodes D541 to D545

\*3: To each key and SW

## 2. NM93C46N (IC703) Memory

### ● Pin Assignment

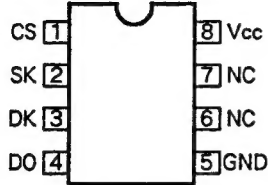

Top View

### ● Pin Function

Pin No.	Pin Name	Functions
1	CS	Chip Select
2	SK	Serial Data Clock
3	DI	Serial Data Input
4	DO	Serial Data Output
5	GND	Ground
6	—	NC
7	—	NC
8	VCC	Power Supply

## 3. LC7570 (IC702) BLE Data conversion

### ● Pin Function

Pin No.	Pin Name	Functions
1	—	To GNDC
2	WR	For the data in latch from the CPU
3	SCK	For the data in clock from the CPU
4	DAT1	Data in from the CPU
5	—	To Vcc +5V
6	XBLK	All outputs L. REQUEST input
7	GND	To GNDC
8	—	—
9	—	—
10	—	—
11	SELB	2-bit monitor switching selection
12	SELA	
13	NRSS	Not used
14	NRS1	1 bit of the 2-bit Dolby NR selection
15	SOLB	Mechanism solenoid power reduction selection. H: ON
16	FSO2	3-bit 1/f high frequency boost amount selection (3-bit output data=0 to 7) 0: Min 7: Max
17	FSO1	
18	FSO0	
19	RECV	Meter amplifier DC output recovery fast. H: ON
20	BLE	When BLE: H. Circuit selection
21	TOCD	CONT to CD (for CD-SYNCHRO) L: PLAY to CD. REQUEST

Pin No.	Pin Name	Functions
22	XMPX	MPX circuit and LED driving. L: ON
23	LREC	REC IND LED driving. H: ON
24	LPLY	PLAY IND LED driving. H: ON
25	SEQ1	SOUND-EQ type selection (2-bit)
26	SEQ0	
27	FSE1	Filter selection during BLE
28	FSE0	
29	BIA1	Auto BLE compensation data output Bias 2-bit
30	BIA0	
31	MEQ3	Auto BLE compensation data output Mid-EQ 4-bit
32	MEQ2	
33	MEQ1	
34	MEQ0	
35	HEQ3	Auto BLE compensation data output High-EQ 4-bit
36	HEQ2	
37	HEQ1	
38	HEQ0	
39	LEV3	Auto BLE compensation data output Level 4-bit
40	LEV2	
41	LEV1	
42	LEV0	

# 10. FL INFORMATION

● V1501 (RAW1121)

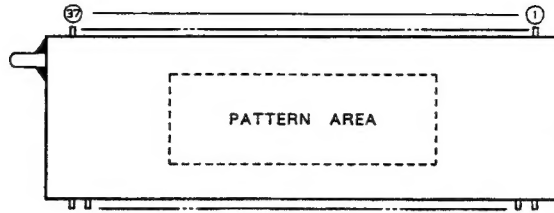

### Pin Connection

PIN NO.	3	3	3	3	3	3	3	2	2	2	2	2	2	2	1	1	1	1	1	1	1	1	1	1	1	1					
CONNECTION	F	F	N	P	P	P	N	P	P	P	P	P	P	P	P	P	P	N	0	9	8	7	6	5	4	3	2	1			
	2	2	P	1	2	3	4	C	5	6	7	8	9	10	5	7	1	4	3	2	6	C	6	G	G	G	G	G	C	P	1

NOTE 1) F1, F2 --- Filament      4) 1G~10G --- Grid  
 2) NP ----- No pin  
 3) NC ----- No connection

### Grid Assignment

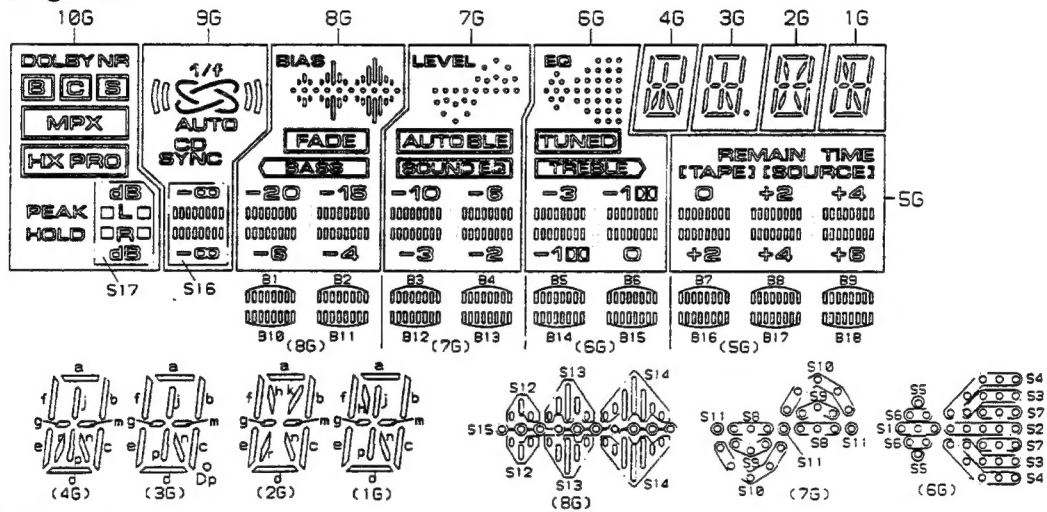

### Anode Connection

	10G	9G	8G	7G	6G	5G	4G	3G	2G	1G
P1	S17	S16	B1	B3	B5	B7	a	a	a	a
P2	HOLD	GR SYNC	B10	B12	B14	B16	b	b	b	b
P3	PEAK	AUTO	B2	B4	B6	B8	f	f	f	f
P4	HX PRO	1/f	B11	B13	B15	B17	g	g	g	g
P5	MPX	( )	-6 -4	-3 -2	-100 0	+2 +4 +6	m	m	m	m
P6	( )	( )	-20 -15	-10 -6	-3 -100 0	+2 +4	c	c	c	c
P7	( )	( )	BASS	BOUNCES	TREBLE	B9	e	e	e	e
P8	( )	( )	S12	AUTOBLE	TUNED	B18	d	d	d	d
P9	DOLBY NR	( )	S13	S8	S1	REMAIN	j.p	j.p	h	j.p
P10	-	( )	S14	S9	S2	TIME	r	Dp	n	h
P11	-	-	S15	S10	S3	[SOURCE]	n	n	r, k	n
P12	-	-	FADE	S11	S4	[TAPE]	-	-	-	-
P13	-	-	-	-	S5	-	-	-	-	-
P14	-	-	-	-	S6	-	-	-	-	-
P15	-	-	-	-	S7	-	-	-	-	-
P16	-	-	-	-	EQ	-	-	-	-	-
P17	-	-	-	LEVEL	-	-	-	-	-	-
P18	-	-	BIAS	-	-	-	-	-	-	-



## 11. PANEL FACILITIES

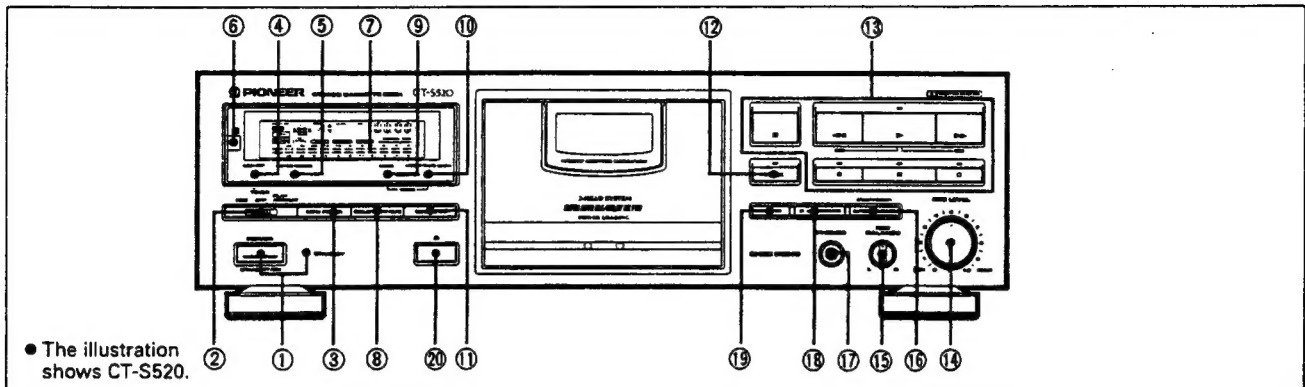

① **POWER STANDBY/ON switch and STANDBY indicator**

The POWER switch activates the secondary transformer only. Even when the switch is in the STANDBY position, there will be a power flow to the deck's circuits as long as the power cord is connected to a power outlet.

② **TIMER mode/repeat play switch (TIMER REC/OFF/PLAY-REPEAT)**

③ **MPX FILTER button**

④ **Display off button (DISP OFF)**

Press to turn the function display on and off.

⑤ **Level meter range selector button**

Press to select wide or expanded range on the level meter.

⑥ **Remote sensor window (CT-S520 only)**

⑦ **Function display**

⑧ **Dolby\* NR button (DOLBY NR OFF/B/C)**

- \*  
• *Dolby noise reduction and HX Pro headroom extension manufactured under license from Dolby Laboratories Licensing Corporation. HX Pro originated by Bang & Olufsen.*
- *"DOLBY"; the double-D symbol  and "HX PRO" are trademarks of Dolby Laboratories Licensing Corporation.*

⑨ **Tape counter mode button (COUNTER MODE)**

⑩ **Counter reset/tape capacity selector button (COUNTER RESET/TAPE CAPA)**

⑪ **SOUND EQ button (CT-S520 only)**

⑫ **FLEX (1/f) button**

⑬ **Operation buttons**

- ◀◀/MS : Rewind/music search
- : Stop
- ▶ : When pressed during stop, begins playback.
- ▶▶/MS : Fast forward/music search
- : Recording
- || : When pressed during playback or recording, pauses playback or recording. When pressed during pause, resumes play or starts recording.
- : Recording mute

⑭ **Recording level control (REC LEVEL)**

⑮ **Recording balance control (REC BALANCE)**

⑯ **SUPER AUTO BLE START/CLEAR button**

⑰ **Headphones jack (PHONES)**

⑱ **CD · DECK SYNCHRO recording button (CD SYNCHRO)**

⑲ **Monitor selector button (MONITOR)**

Used to monitor the source sound or just recorded source during recording.

- When the unit is set to record or playback mode, the TAPE indicator light up and the monitor mode is automatically selected.

⑳ **OPEN/CLOSE button (CT-S520)**

If the tape is moving (recording), press the stop (■) button before pressing this button.

If this button is pressed when the unit is in standby mode, the cassette door opens and the function display is turned on automatically.

㉑ **Eject button (⏏) (CT-S420)**

- If the tape is moving (recording, playback, tape winding, etc.), press the stop (■) button before pressing this button.

## 12. SPECIFICATIONS

System	4-track, 2-channel stereo
Heads	Combined "Hard Permalloy" recording/playback head × 1 "Ferrite" erasing head × 1
Motor	DC servo capstan motor × 1 DC reel motor × 1 DC loading motor × 1 (CT-S520 only)
Wow and Flutter	No more than 0.05% (WRMS, JIS) No more than ±0.14% (DIN)
Fast Winding Time	Approx. 90 seconds (C-60 tape)
Frequency Response (at -20 dB recording level)	
TYPE IV (Metal) tape	20 to 21,000 Hz (±6 dB)
TYPE II (CrO <sub>2</sub> ) Tape	20 to 19,000 Hz (±6 dB)
TYPE I (Normal) Tape	20 to 19,000 Hz (±6 dB)
Signal-to-Noise Ratio (Dolby NR OFF)	More than 59 dB
Noise Reduction Effect	
Dolby B-type NR ON	More than 10 dB (at 5 kHz)
Dolby C-type NR ON	More than 19 dB (at 5 kHz)
Harmonic Distortion	No more than 0.6% (at -4 dB: 160 nwb/m)
Input (Sensitivity)	
LINE (INPUT)	100 mV (Input impedance 50 kΩ)
Output (Reference level)	
LINE (OUTPUT)	0.5 V (Output impedance 3.0 kΩ)
Headphones (PHONES)	0.63 mW (Load impedance 8 Ω)

### Miscellaneous

#### Power requirements

U.K., model	AC 230—240 Volts~, 50/60 Hz
European model	AC 220—230 Volts~, 50/60 Hz
Power consumption	20 W
Dimensions	420 (W) × 125 (H) × 280 (D) mm
Weight	
[CT-S520]	4.2 kg (except for U.K. model) 4.5 kg (U.K. model only)
[CT-S420]	4.1 kg (except for U.K. model) 4.4 kg (U.K. model only)